



Grandstream Networks, Inc.

GWN771x Series

User Manual



INTRODUCTION

The GWN7711(P) Series are Layer 2 lite managed switches for small to medium-sized businesses, offering scalable, secure, high-performance networks. They support VLAN for traffic segmentation, QoS for prioritizing traffic, IGMP snooping for network optimization, and robust security features. The PoE model provides dynamic PoE output for various devices, including IP phones and cameras. Easy management options include a local web interface and GDMS Networking, suitable for hotels, home offices, and small-to-medium businesses.

The GWN7710R is a 6-Port (5GE+1SFP) Outdoor Lite Managed PoE Switch with an IP66-rated shell for harsh weather conditions. It builds scalable, secure, high-performance networks in scenic locations like hotels and restaurants. It supports VLAN segmentation, various QoS management modes, bandwidth control, and Storm Control for enhanced performance. Integrated PoE supports long-distance power supply and data transmission. Managed via a local web interface and GDMS Networking, its compact design supports versatile installation methods for indoor and outdoor areas.

PRODUCT OVERVIEW

Feature Highlights

- o **GWN7711**

 <p>A black, rack-mountable switch with 8 RJ45 ports labeled 1-8 and a power jack labeled SV. The model name GWN7711 is printed below the ports.</p>	<ul style="list-style-type: none">● 8 Gigabit Ethernet ports● Built-in QoS allows for prioritization of network traffic.● Whisper Quiet: fanless● LED Indicators; Per Port: Link/Activity/PoE power state Per Device: Power● Storm Control to monitor traffic levels
--	--

GWN7711 Features at a glance

- o **GWN7711P**

 <p>A black, rack-mountable switch with 8 RJ45 ports labeled 1-8. The first four ports are marked with yellow and green labels 'PoE out'. The model name GRANDSTREAM GWN7711P is printed on the top left. A power jack is visible on the right side.</p>	<ul style="list-style-type: none">● 8 Gigabit Ethernet ports● 4 PoE Out ports● Built-in QoS allows for prioritization of network traffic.● Whisper Quiet: fanless● LED Indicators; Per Port: Link/Activity/PoE power state Per Device: Power● Storm Control to monitor traffic levels.
---	---

GWN7711P Features at a glance

- o **GWN7710R**

 <p>GWN7710R</p>	<ul style="list-style-type: none"> ● 5 Gigabit RJ45 ports (4 PoE output ports, 1 PoE input port) ● IP66 dustproof and waterproof rating; Wide operating temperature range: -40°C to 60°C ● Built-in QoS allows for prioritization of network traffic ● LED Indicators; Per port: Link/Activity/PoE Power state Per device: Power ● IEEE 802.3 at/af or 24V /48V DC passive PoE out, Up to 30W on each port
--	---

GWN7710R Features at a glance

GWN7711/P Technical Specifications

	GWN7711	GWN7711P
Network Protocol	Network Protocol IPv4, IEEE 802.3i, IEEE 802.3u, IEEE 802.3ab, IEEE 802.3x, IEEE 802.1p, IEEE 802.3af, IEEE 802.3at	
Gigabit Ethernet Ports	8	
PoE Out Ports	/	4
Power Supply	External 5VDC/0.6A	External 48-53.5VDC/1.22A
PoE Output	/	<p>Port 1-4 compliance with the 802.3af/at standard:</p> <ul style="list-style-type: none"> ● Support up to 30W on each PoE port, total 60W Power Budget. <p>Port 1-4 can also switch to 24VDC Passive PoE-Out mode via WebUI:</p> <ul style="list-style-type: none"> ● Port 1 (up to 30W): 24VH 1.3A pins 1,2,4,5 (+) 3,6,7,8 (-). ● Port 2-4 (up to 15W): 24V 0.65A pins 4,5 (+) 7,8 (-).
Max Total PoE Output Power	/	60W
Maximum Output Power per PoE Port	/	30W
Auxiliary Ports	1x Reset Pinhole	
Forwarding Mode	Store-and-forward	

Total non-blocking throughput	8Gbps	
Switching Capability	16Gbps	
Jumbo Frame	2K/3K/4K/5K/6K/7K/8//9K/12K/15K	
Forwarding Rate	11.9Mpps	
MAC	8K MAC address capacity	
VLAN	<ul style="list-style-type: none"> • 4K VLANs • Port-based VLAN, 802.1Q VLAN 	
LAG	4	
Multicast	IGMP Snooping, Report Message Suppression	
QoS	<ul style="list-style-type: none"> • Auto prioritization of the incoming port of the packet • Priority Mapping • Queue scheduling, including SP, WRR, WFQ • Supports port priority, 802.1p priority and DSCP priority • Bandwidth control • Storm control • Rate limit 	
DHCP	DHCP client	
Maintenance	Backup and restore, system reboot, factory reset, firmware upgrade, monitoring including port statistics, port mirroring, cable test and loop prevention, Ping watchdog	
Security	<ul style="list-style-type: none"> • Storm control • Port VLAN isolation • Filtering MAC address • Kensington Security Slot (Kensington Lock) support 	
Mounting	Desktop/Wall-mount	
LED Indicators	<ul style="list-style-type: none"> • Per Port: Link/Activity – Green • Port 1-4: PoE power state – Yellow • Per Device: Power – Green 	
Environmental	<ul style="list-style-type: none"> • Operating Temperature: 0 to 40 °C (32 to 104 °F) • Storage Temperature: -20 to 60 °C (-4 to 140 °F) • Operating Humidity: 10% to 90% Non-condensing • Storage Humidity: 10% to 90% Non-condensing 	
Dimensions (LxWxH)	<ul style="list-style-type: none"> • Unit: 164 x 80 x 30mm • Package: 202 x 166 x 54mm 	<ul style="list-style-type: none"> • Unit: 190 x 100 x 28mm • Package: 230 x 210 x 51mm

Enclosure	Plastic	Metal
Weight	Unit: 0.17kg Entire Package: 0.38kg	Unit: 0.44kg Entire Package: 0.92kg
Package Content	1x Switch, 1x QIG, 1x Power Adapter	
Compliance	FCC, CE, RCM, IC	

GWN7711(P) *Technical Specifications*

GWN7710R Technical Specifications

Network Protocol	IPv4, IEEE 802.3i, IEEE 802.3u, IEEE 802.3ab, IEEE 802.3x, IEEE 802.1p, IEEE 802.3af, IEEE 802.3at
Communication Ports	<ul style="list-style-type: none"> • 5*Gigabit Ethernet Ports • 1 * 1G/2.5G SFP Port
Power Supply	<ul style="list-style-type: none"> • 12V-57V DC input • Standard PoE /PoE+/PoE++
PoE In and PoE Out Ports	<ul style="list-style-type: none"> • PoE In: Port5; • PoE Out: Port1~Port4
PoE Output	<ul style="list-style-type: none"> • Standard PoE output Mode (Default) • Passive 24VDC or 48VDC output Mode (Configured via UI)
PoE Output Budget	<ul style="list-style-type: none"> • Powered by Standard PoE In (802.3af/at/bt): 802.3af input: 3W output budget 802.3at input: 15W output budget 802.3bt input: 60W output budget • Powered by DC In (12V~57V): DC In>12V: 60W output budget DC In>24V: 72W output budget DC In>36V: 100W output budget
Max Output Power per Port	<ul style="list-style-type: none"> • Standard PoE output Mode: Port 1~Port4 up to 30W on each PoE port; • Passive PoE output Mode: Port 1: 4-pair 48V DC up to 60W or 4-pair 24V DC up to 30W Port 2~Port4: 2-pair 48V DC up to 30W or 2-pair 24V DC up to 15W * Note: •4-Pair: Powered on pins : 1,2,4,5(+), 3,6,7,8(-) •2-Pair: Powered on pins : 4,5(+), 7,8(-)
Auxiliary Port	1x Reset Pinhole
Forwarding Mode	Store-and-forward
Total non-blocking throughput	6Gbps
Switching Capability	15Gbps
Jumbo Frame	2K/3K/4K/5K/6K/7K/8K/9K/12K/15K

Forwarding Rate	11.16Mpps
Pack Buffer	4Mbits
MAC	8K MAC address capacity
VLAN	<ul style="list-style-type: none"> • Supports up to 32 VLANs (out of 4K VLAN IDs) • port-based VLAN, 802.1Q VLAN
LAG	3
Multicast	<p>IGMP Snooping ,Report Message Suppression</p> <ul style="list-style-type: none"> • Auto prioritization of the incoming port of the packet • Supports port priority, 802.1P priority, and DSCP priority
QoS	<ul style="list-style-type: none"> • Bandwidth control • Storm Control • Rate limit
DHCP	DHCP client
Maintenance	Backup and restore, System reboot, Factory Reset, Firmware upgrade, Monitoring including port statistics, Port mirroring, Cable test and loop prevention, Ping
Security	<ul style="list-style-type: none"> • Storm control • Port VLAN isolation • Filtering MAC address
Mounting	<p>Pole/Wall-Mount//DIN-Rail</p> <ul style="list-style-type: none"> • Per device System on : Green
LED Indicators	<ul style="list-style-type: none"> • Per Ethernet port Link/Activity: Green; • Per Passive PoE out port 48VDC: Orange • Per Passive PoE out port 24VDC: Blue
ESD	± 10kV Air, ± 16kV Contact
Surge	CM 6KV
Environmental	<ul style="list-style-type: none"> • Operating Temperature: -40 to 60 °C (-40 to 140 °F) • Storage Temperature: -40 to 70 °C (-40 to 158 °F) • Operating Humidity: Support IP66 waterproof • Storage Humidity: 10% to 95% Non-condensing
Dimensions (L x W x H)	<p>Unit: 210 x 150 x 52mm</p> <p>Package: 466 x 286 x 258mm</p>
Weight	<p>Unit: 0.75KG</p> <p>Entire Package :1.35KG</p>
Package Content	1x Switch, Rack-mounting Standard Brackets , 1x QIG,4x assembled screw, 4x expansion screw ,2 x Metal straps,1x Phoenix connector
Compliance	FCC, CE, RCM, IC

INSTALLATION

Before deploying and configuring the GWN771x switch, the device needs to be properly powered up and connected to the network. This section describes detailed information on the installation, connection, and warranty policy of the GWN771x switch.

Package Contents

○ GWN7711(P)

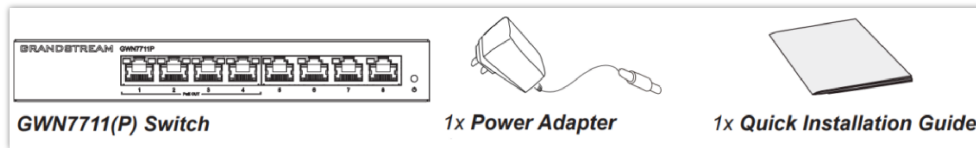

GWN7711P package contents

○ GWN7710R

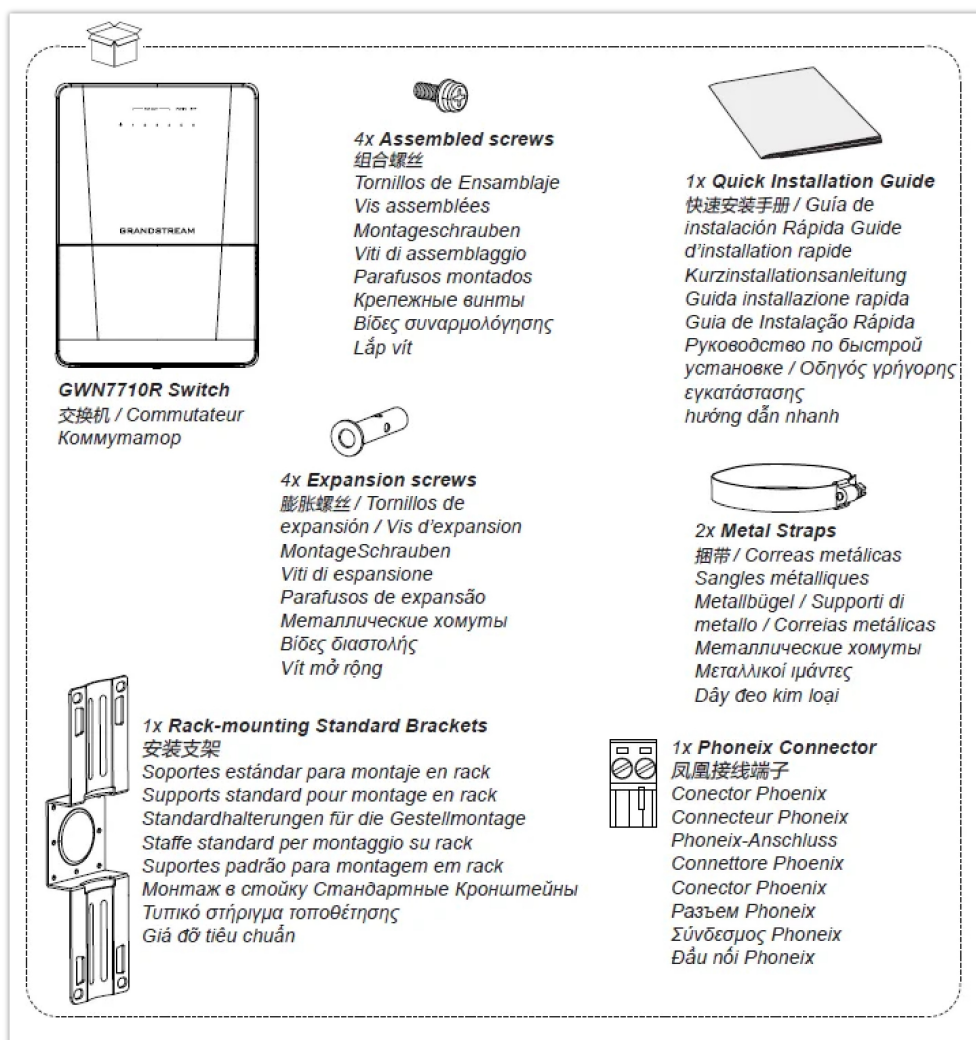

GWN7710R Package Content

Port Description

○ GWN7711(P)

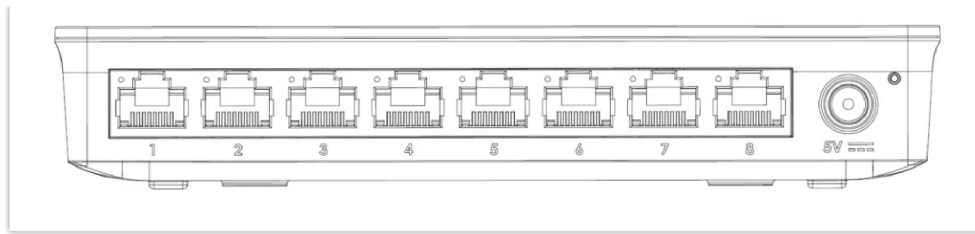

GWN7711 Ports

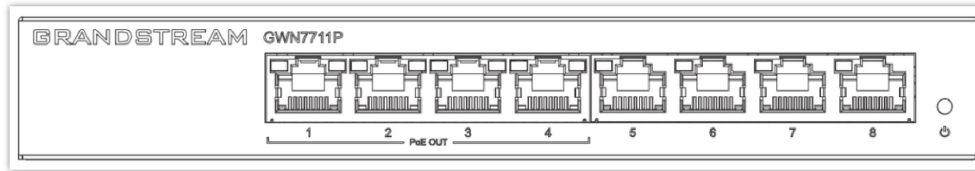

GWN7711P Ports Front View

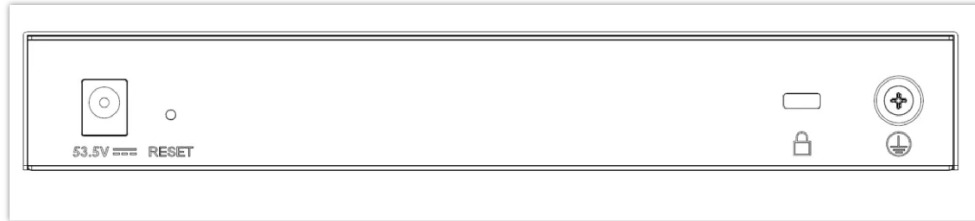

GWN7711P Ports Back View

	GWN7711	GWN7711P
Gigabit Ethernet Ports	8	
PoE Out Ports	/	4
PoE Output	/	<p>Port 1-4 compliance with the 802.3af/at standard:</p> <ul style="list-style-type: none"> Support up to 30W on each PoE port, total 60W Power Budget. <p>Port 1-4 can also switch to 24VDC Passive PoE-Out mode via WebUI:</p> <ul style="list-style-type: none"> Port 1 (up to 30W): 24VH 1.3A pins 1,2,4,5 (+) 3,6,7,8 (-). Port 2-4 (up to 15W): 24V 0.65A pins 4,5 (+) 7,8 (-).
Auxiliary Port	1x Reset Pinhole	
Power Outlet	5V	DC 53.5V
Grounding Terminal	/	Safely divert electrical surges and reduce interference
Kensington Lock	/	Physical security lock to stop theft and unauthorized movement of the unit

GWN7711(P) Ports

o GWN7710R

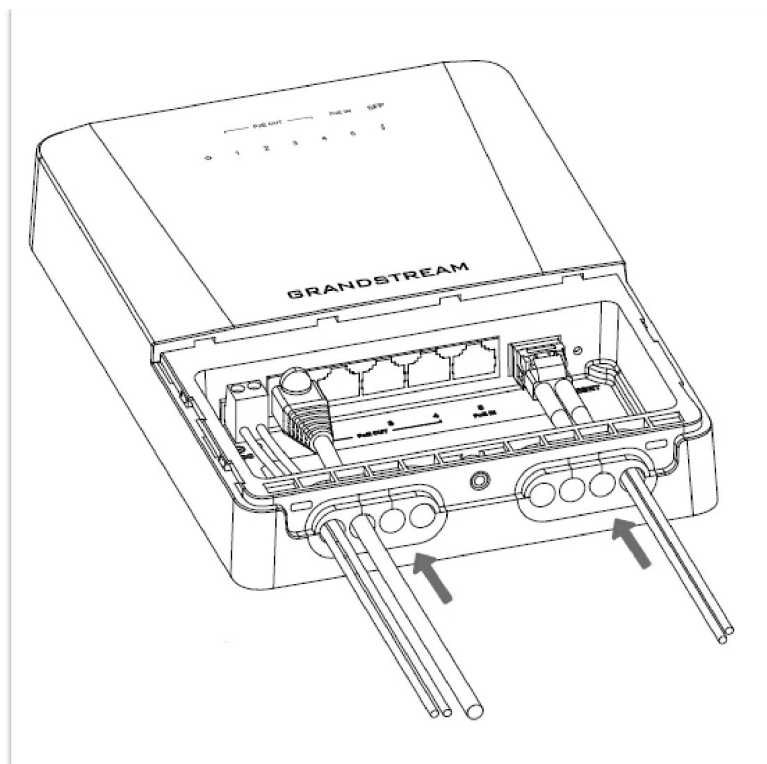

	GWN7710R
Gigabit Ethernet Ports	5 (PoE Out Ports: 4, PoE IN Ports: 1) <ul style="list-style-type: none"> • Powered by Standard PoE In (802.3af/at/bt): <ul style="list-style-type: none"> 802.3af input: 3W output budget 802.3at input: 15W output budget 802.3bt input: 60W output budget • Powered by DC In (12V~57V): <ul style="list-style-type: none"> DC In>12V: 60W output budget DC In>24V: 72W output budget DC In>36V: 100W output budget
2.5G SFP Port	1
2-pin DC IN port	Passive 24VDC or 48VDC output Mode (Configured via UI)
Auxiliary Port	1x Reset Pinhole

GWN7710R Ports

Grounding and Accessing GWN771x

Grounding the GWN7711/P Switch

1. Remove the ground screw from the back of the switch, and connect one end of the ground cable to the wiring terminal of the switch.
2. Put the ground screw back into the screw hole, and tighten it with a screwdriver.
3. Connect the other end of the ground cable to the other device that has been grounded or directly to the terminal of the ground bar in the equipment room.

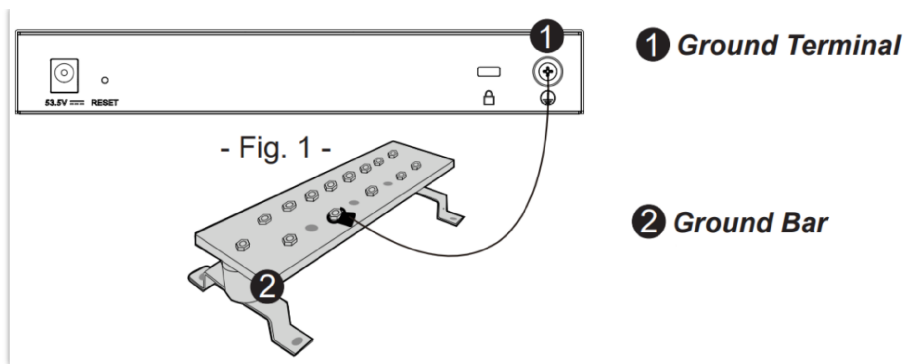

GWN7711P Grounding the switch

Note:

Ground cable is not provided; Switch grounding is only supported on GWN7711P.

Safety Compliances

The GWN7711(P) Switch complies with FCC/CE and various safety standards. The GWN7711(P) power adapter is compliant with the UL standard. Use the universal power adapter provided with the GWN7711(P) package only. The manufacturer's warranty does not cover damages to the device caused by unsupported power adapters.

Warranty

If GWN7711(P) Switch was purchased from a reseller, please contact the company where the device was purchased for replacement, repair or refund. If the device was purchased directly from Grandstream, contact our Technical Support Team for an RMA (Return Materials Authorization) number before the product is returned. Grandstream reserves the right to remedy the warranty policy without prior notification.

Grounding the GWN7710R Switch

1. Remove the ground screw from the back of the device, and connect one end of the ground cable to the wiring terminal of the device.
2. Put the ground screw back into the screw hole, and tighten it with a screwdriver.
3. Connect the other end of the ground cable to another device that has been grounded or directly to the terminal of the ground bar in the equipment room.

Note

Ground cable is not provided.

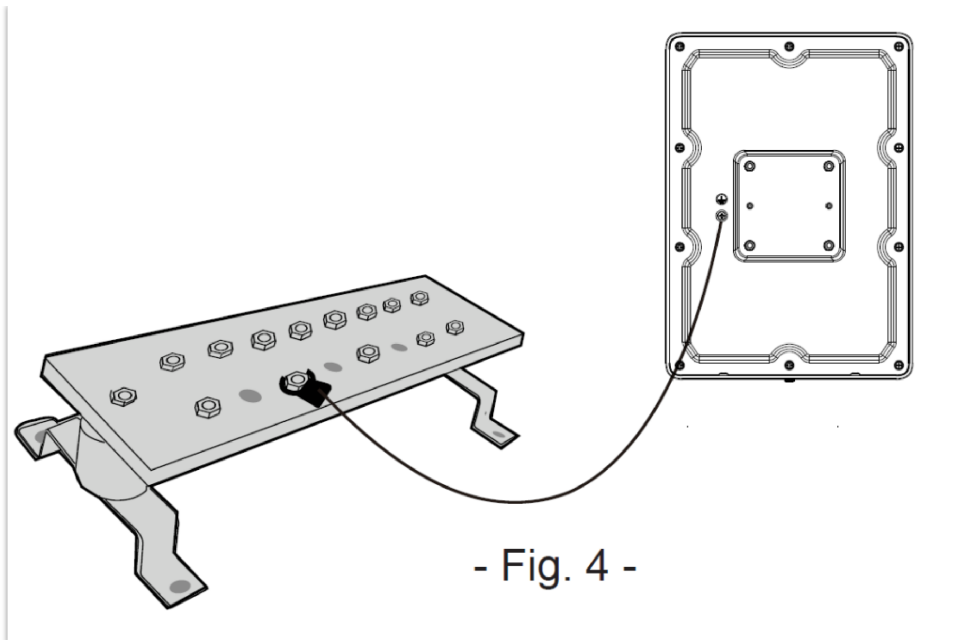

GWN7710R Grounding Terminal

Mounting methods for the GWN7710R

Pole Mount

1. Attach the bracket to the back of the unit using the assembled screws.
2. Open the metal straps by turning the locking mechanism counterclockwise. You can loosen it by hand or use a flathead screwdriver.
3. Straighten out the end of the metal straps and slide it through the back of the bracket.
4. Wrap the metal strap around the pole and use a flathead screwdriver to tighten the locking mechanism by turning it clockwise

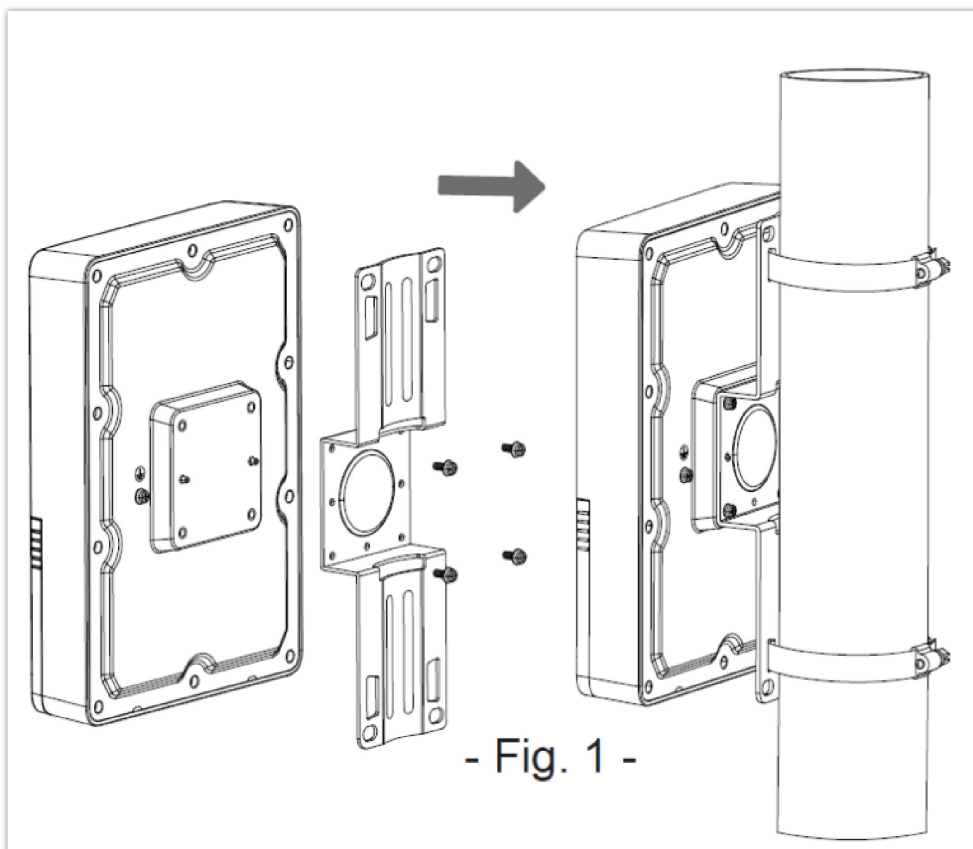

GWN7710R Pole Mount

Wall Mount

1. Rotate the bracket 90° and attach it horizontally on the back of the device with assembled screws.
2. Drill four holes on the wall referring to the positions of the ones on the bracket. Then, fix an expansion screw in each hole.
3. Attach the device by securing the bracket with the expansion screws on the wall.

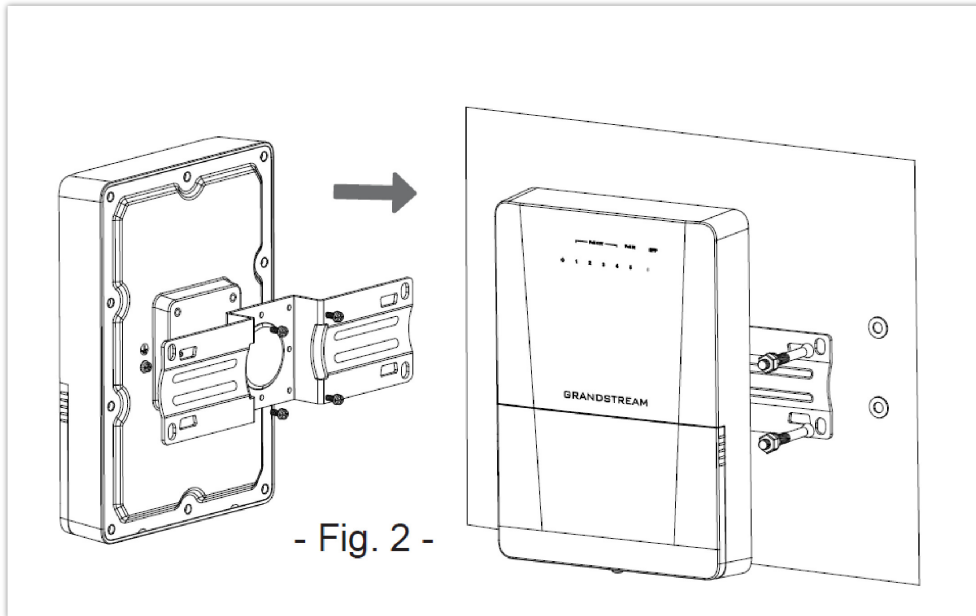

GWN7710R Wall Mount

DIN-Rail Mount

1. Attach the DIN-Rail bracket with screws on the back of the device.
2. Clamp the DIN-Rail bracket to the universal guide rail.

Note

DIN-Rail bracket is not provided.

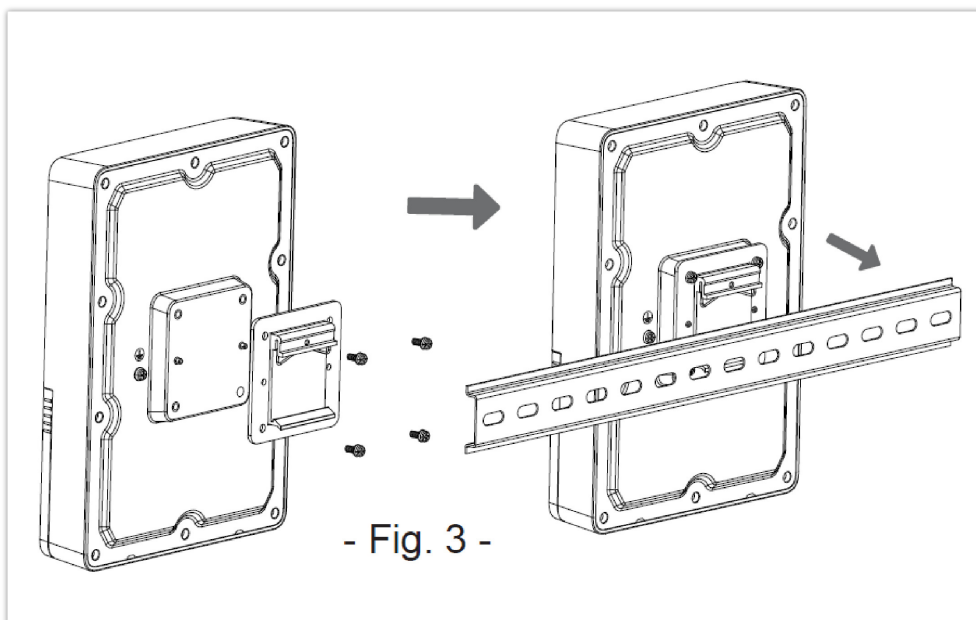

GWN7710R DIN Rail Mount

Cable Installation For GWN7710R

1. Insert the cable through the hole under the device housing and connect it to the corresponding interface, then insert the other end of the cable into the waterproof silicone plug.
2. Insert the waterproof silicone plug into the designated position under the device housing.
3. Push the anti-water shell in the direction of the arrow until the bottom shell is completely closed, and then use screws to fix it.

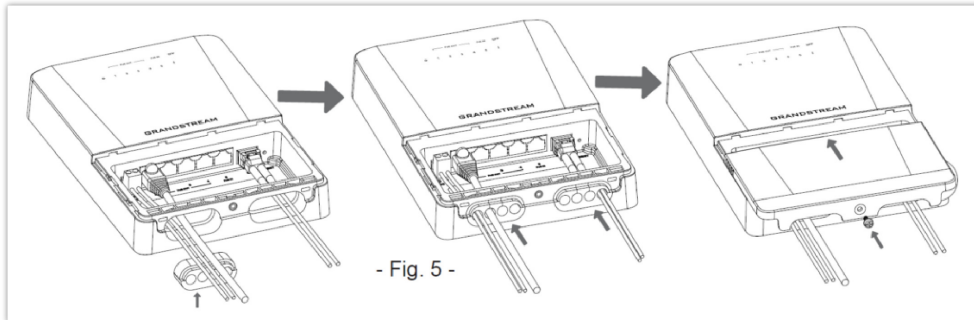

- Fig. 5 -

GWN7710R Cable Installation

GWN7710R PoE Output mode

The table below displays the cables for configuring Power over Ethernet (PoE) to connected devices in outdoor environments. PoE Output mode enables the switch to provide power to devices like outdoor access points, surveillance cameras, or other PoE-enabled equipment, simplifying installation by eliminating the need for separate power sources. This setup ensures continuous operation of outdoor network devices, even in remote locations, enhancing network connectivity and management flexibility.

PINS	T568A Color	T568B Color	2-Pair	4-Pair
1	white/green stripe	white/orange stripe		DC +
2	green solid	orange solid		DC +
3	white/orange stripe	white/green stripe		DC -
4	blue solid	blue solid	DC +	DC +
5	white/blue stripe	white/blue stripe	DC +	DC +
6	orange solid	green solid		DC -
7	white/brown stripe	white/brown stripe	DC -	DC -
8	brown solid	brown solid	DC -	DC -

*4-Pair: power on pins 1,2,4,5(+) 3,6,7,8(-) *2-Pair: power on pins 4,5(+) 7,8(-)

GWN7710R PoE Output mode

GWN7710R Deployment Cases

Solar DC + Fiber Optic Cable

This deployment involves installing GWN7710R powered by solar direct current (DC) energy and connected via fiber optic cables outdoors. This setup is ideal for remote locations or areas without reliable power sources, where traditional electrical wiring is impractical. Solar panels generate electricity, which powers the network switches, ensuring continuous connectivity. Fiber optic cables provide high-speed and reliable data transmission over long distances, making them suitable for various outdoor networking applications such as surveillance, environmental monitoring, or rural connectivity.

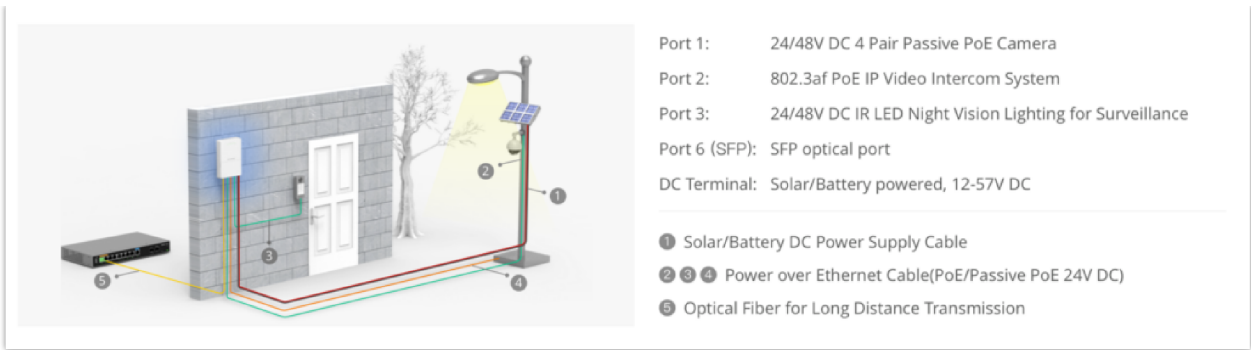

Solar Cable Installation

PoE++ RJ45 Power and Data

This setup uses Power over Ethernet (PoE++) technology to provide both power and data connectivity to outdoor devices via RJ45 connections. This setup eliminates the need for separate power sources for each device, simplifying installation and maintenance. PoE++ delivers higher power levels over Ethernet cables, making it suitable for outdoor applications such as IP cameras, wireless access points, or outdoor lighting, where traditional power sources are not available.



RJ45 Power and Data

GWN7711(P) Deployment Cases

802.1Q VLAN Trunk for Multi-Dedicated SIP Trunking

Using VLAN Trunking to merge multiple ITSP streams into a single port connecting to UCM, and aggregate Internet and IPTV into another port connecting to router and switch.

- Port 1: Access VLAN 10 ITSP 1 SIP trunk
- Port 2: Access VLAN 20 ITSP 2 SIP trunk
- Port 4: Trunk VLAN(10/20) to UCM
- Port 6: Access VLAN 30 Internet service
- Port 7: Access VLAN 40 IPTV service
- Port 8: Trunk VLAN(30/40) to Router

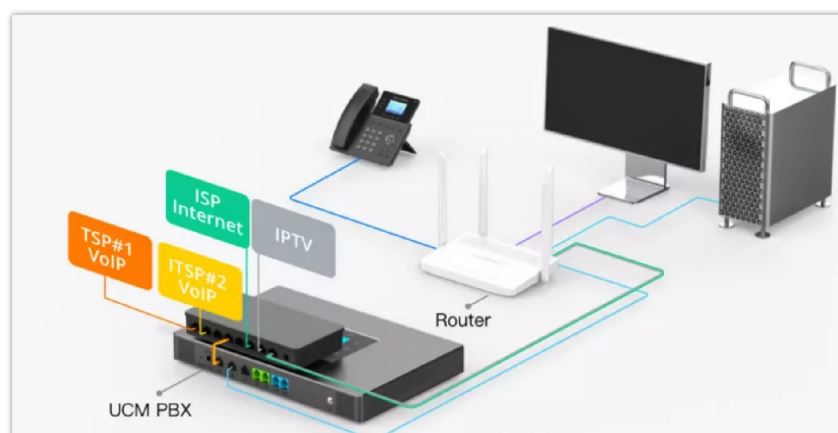

PoE & VLAN Isolation for IP Camera

Use VLAN to isolate the IP Camera/Internet/IPTV traffic. Use link aggregation to increase upstream bandwidth.

- Port 1: 24V/48V 4 Pair Passive PoE Camera
- Port 2: 24V 2 Pair Passive PoE Camera
- Port 3: 802.3af PoE IP Video Intercom System
- Port 4: Wireless 802.3af PoE AP
- Port 5: Network Equipment PC, printer, etc.
- Port 6: GRP VoIP Phone, etc.
- Port 7-8: Uplink Aggregation Group

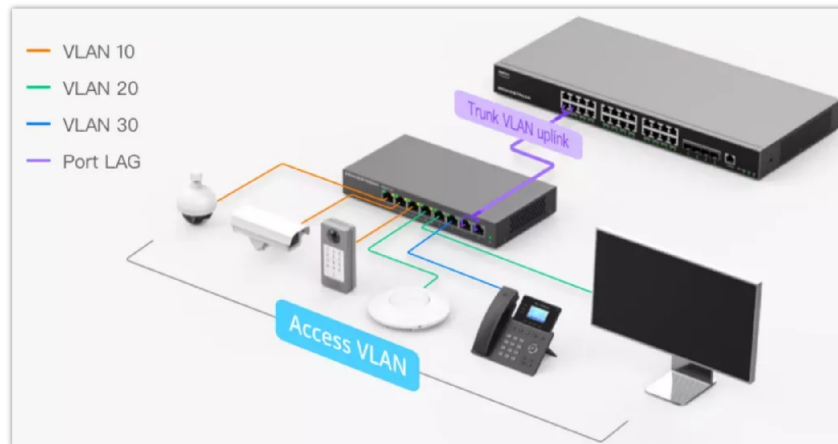

PoE VLAN Isolation for IP Camera

GETTING STARTED

Device LED Indicators

The front panel of the GWN771x has LED indicators for power and interface activities, the table below describes the LED indicators' status.

LED Indicator	Status	Description
Power	Off	Power off.
	Solid green	Power on.
Link/Act	Off	No device is connected.
	Solid green	Port is connected and there is no activity.
	Flashing green	Port is connected and data is transferring.
PoE LED (GWN771IP)	Off	Not providing PoE power.
	Solid yellow	Standard PoE normal power supply (connect PD to negotiate power supply); 24V or 48V forced-mode PoE power supply.

	Flashing yellow	PoE power supply anomaly (Port Overload / 24V Throttling / PSE Throttling).
--	-----------------	---

GWN7711(P) LED Indicators

Below is the LED Indicator for GWN7710R:

LED Indicator	Status		Description
Power	Green	Off	Power off
		On	System power on
	Red	On	Low temperature starting
PoE Out Port	Green	On	Link
		Flashing	Active
	Orange	On	48VDC PoE output; (Force on when passive PoE mode)
		1S On 1S Of	48VDC PoE output overload/Short-circuit
	Blue	On	24VDC PoE output; (Force on when passive PoE mode)
		1S On 1S Of	24VDC PoE output overload/Short-circuit
PoE In Port	Green	On	Link
		Flashing	Active
	Orange	On	Powered by PoE In
SFP	Green	On	Link
		Flashing	Active

GWN7710R LED Indicators

Access and configure

Note:

If no DHCP server is available, the GWN771x default IP address is 192.168.0.254.

Login using the Web UI

1. A PC uses a network cable to correctly connect any RJ45 port of the switch.
2. Set the Ethernet (or local connection) IP address of the PC to 192.168.0.x ("x" is any value between 1-253), and the subnet mask to 255.255.255.0, so that it is in the same network segment with the switch IP address. If DHCP is used, this step could be skipped.

3. Type the switch's management IP address `http://` in the browser, and enter username and password to log in. (The default administrator username is "admin" and the default random password can be found on the sticker on the GWN771x switch).

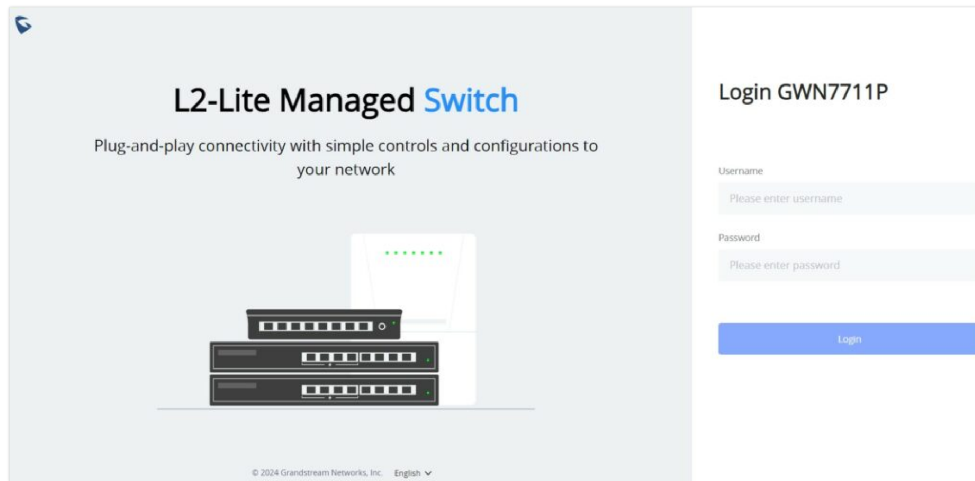

GWN771x login page

Configure using GDMS Networking/GWN Manager

Type <https://www.gdms.cloud> (`https://<gwn_manager_IP>` for GWN Manager) in the browser, and enter the account and password to log in to the cloud platform. If you don't have an account, please register first or ask the administrator to assign one for you. To add GWN switch to GDMS Networking/GWN manager refer to online documentation: <https://documentation.grandstream.com>.

WebUI Configuration

GWN771x WebUI includes 9 main sections to configure and manage the switch and check the connection status.

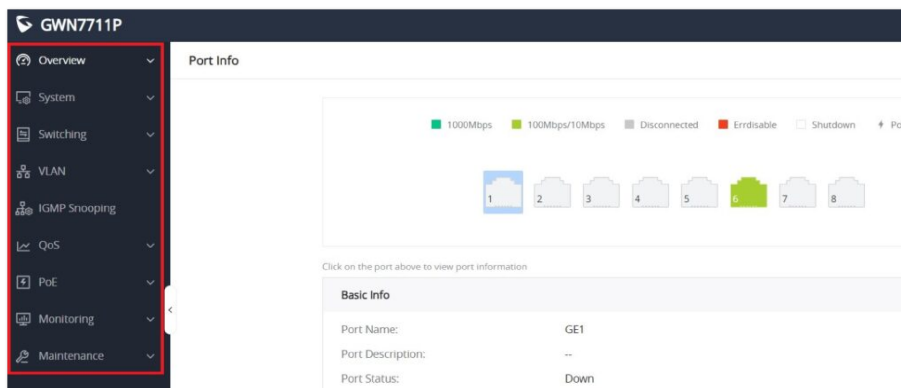

WebUI configuration

Search

GWN771x Switches have search functionality to help the user find the right configuration, settings, parameters, etc.

On the top of the page, there is a search icon, the user can click on it and then enter the keyword relevant to his search, and then he will get all the possible locations of that keyword.

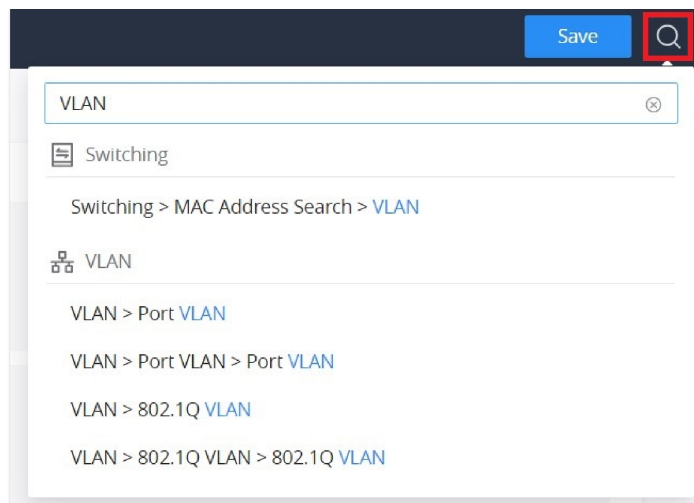

Search

Language

To change the language on the GWN771x switch interface:

- Navigate to the top right corner of the interface where the username is displayed.
- Click on the drop-down menu next to the username.
- Select "Language" from the drop-down options.
- After selecting the language, the interface will switch to the chosen language.

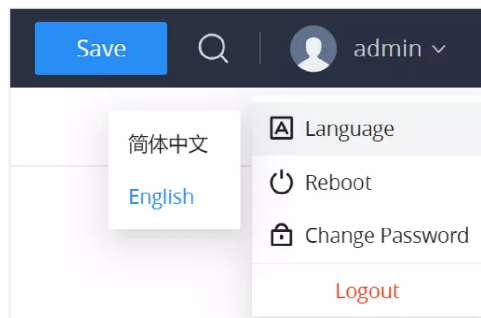

Language

Reboot

To reboot the GWN771x switch:

- Navigate to the top right corner of the interface where the username is displayed.
- Click on the drop-down menu next to the username.
- Select "Reboot" from the drop-down options.
- Confirm the action to reboot the device.
- The device will automatically restart after a brief delay.

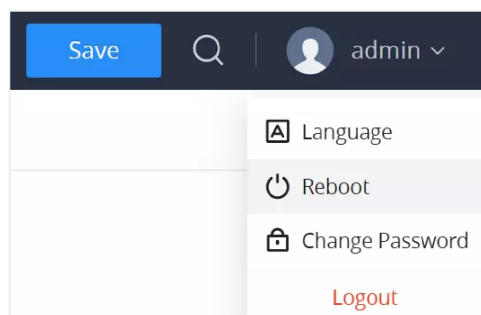

Reboot

Change Password

To change the password on your GWN771x switch:

- Navigate to the top right corner of the interface where the username is displayed.
- Click on the drop-down menu next to the username.
- Select "Change Password" from the drop-down options.
- A "Change Password" dialog box will appear.
- Enter the current password in the **Current Password** field.
- In the **New Password** field, input a new password that meets the criteria: it must contain 8-32 characters and include at least two of the following: digits, letters, and special characters (e.g., `admin,123`).
- Enter the same password in the **Confirm New Password** field.
- Click "Complete" to apply the changes.

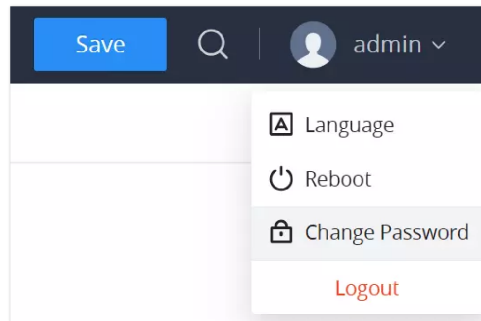

Change password option

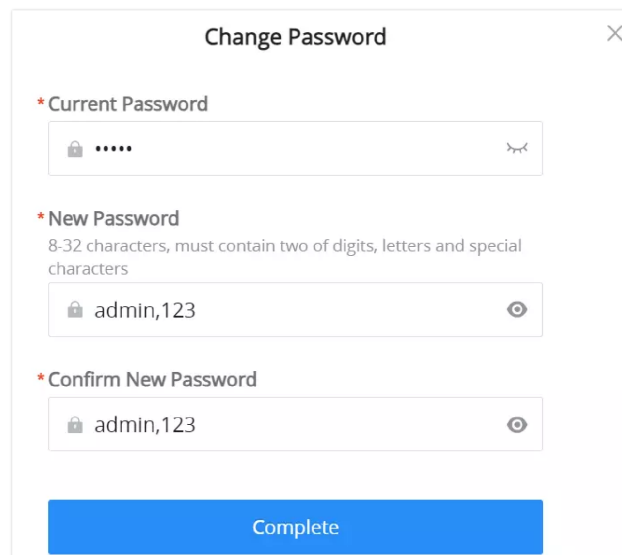
A screenshot of a 'Change Password' dialog box. It has a title bar with 'Change Password' and a close button. The form contains three fields: '* Current Password' (masked with dots), '* New Password' (with a note: '8-32 characters, must contain two of digits, letters and special characters'), and '* Confirm New Password' (with the same note). The 'New Password' and 'Confirm New Password' fields contain the text 'admin,123'. At the bottom, there is a blue 'Complete' button.

Change password

Logout

To log out from the GWN771x switch:

- Navigate to the top right corner of the interface where the username is displayed.
- Click on the drop-down menu next to the username.
- Select "Logout" to safely log out of the current session.

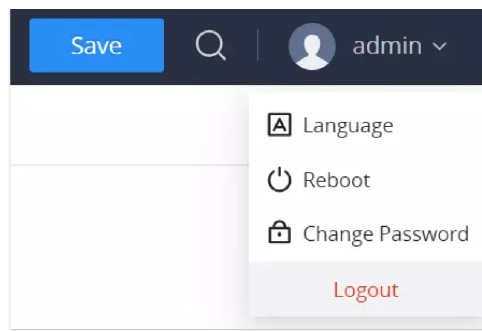

Logout

OVERVIEW

The overview is the first section that displays System information on the first page "System Info" and Port status on the second page "Port Info". This section provides the user with a general and global view of the GWN771x system and port status for easy monitoring.

System Info

System Info is the first page after successfully logging into the GWN771x Web Interface. It provides an overall view of the GWN771x Switch information like, Device name, MAC Address, System Version, etc.

To name the device please click on , then enter the desired name.

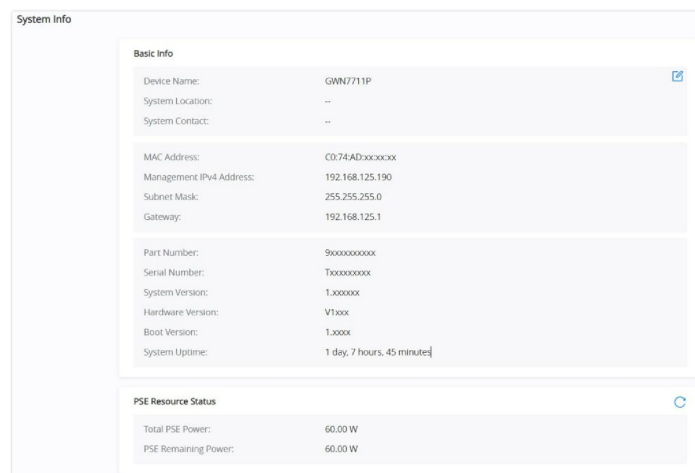

System Info





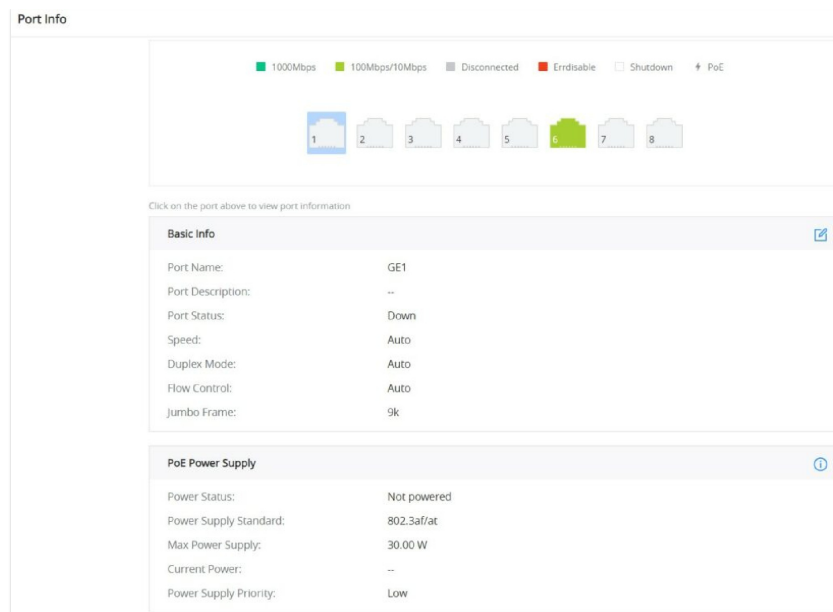

Port Info

This page displays the status for each port on the GWN771x switches indicated by color code (green, red, grey, white, etc) and PoE symbol. Please refer to the figure below:



Port Info page

The following table explains the color code and the symbols used:

	Grey: Linkdown
	White: shutdown
	Green: 1000 Mbps speed
	Light green: 100 Mbps/10 Mbps speed
	Red: ErrDisable
	Symbol: PoE Power is enabled.

Ports Labels and Color code

Note: a PoE symbol and color code combination is also possible. Ex:  in this case, the port is using 1000 Mbps speed and also using PoE at the same time.

There are 3 main sections for each port:

- **Basic Info:** displays info about the port name, speed, status etc.

Note: Click on  to modify the port settings like Description, Speed, Duplex Mode, and Flow Control or to enable or disable the port.

- **PoE Power Supply:** displays PoE Current Power and priority, Status etc.

Note: Click on ⓘ to change PoE settings.

SYSTEM

IP Setting

The **IP Setting** page allows users to configure the switch's IP address and management VLAN. The user can assign a **Management VLAN**, choose between **DHCP** or **Static** for IP configuration, and manually set DNS servers when necessary. These settings are essential for ensuring network management and connectivity.

Management VLAN

The **Management VLAN** field allows users to assign the VLAN used for accessing the switch's management interface. Only ports belonging to this VLAN will have access to the web UI.

Note:

The Management VLAN is only valid for 802.1Q VLAN configurations. The default is VLAN1, and only devices in this VLAN can access the web page.

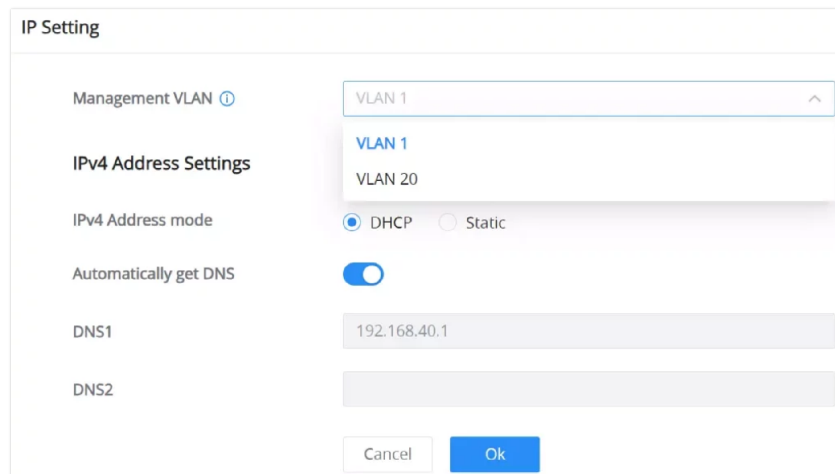

The screenshot shows the 'IP Setting' dialog box. It has a title bar 'IP Setting'. Below it, there are several fields: 'Management VLAN ⓘ' with a dropdown menu showing 'VLAN 1' selected and a list of options including 'VLAN 1' and 'VLAN 20'; 'IPv4 Address Settings' section with 'IPv4 Address mode' set to 'DHCP' (selected) and 'Static' (unselected); 'Automatically get DNS' with a toggle switch turned on; 'DNS1' with the value '192.168.40.1'; and 'DNS2' which is empty. At the bottom, there are 'Cancel' and 'Ok' buttons.

IP Setting Management VLAN

IPv4 Address Settings

These settings define how the switch obtains its IP address and DNS settings.

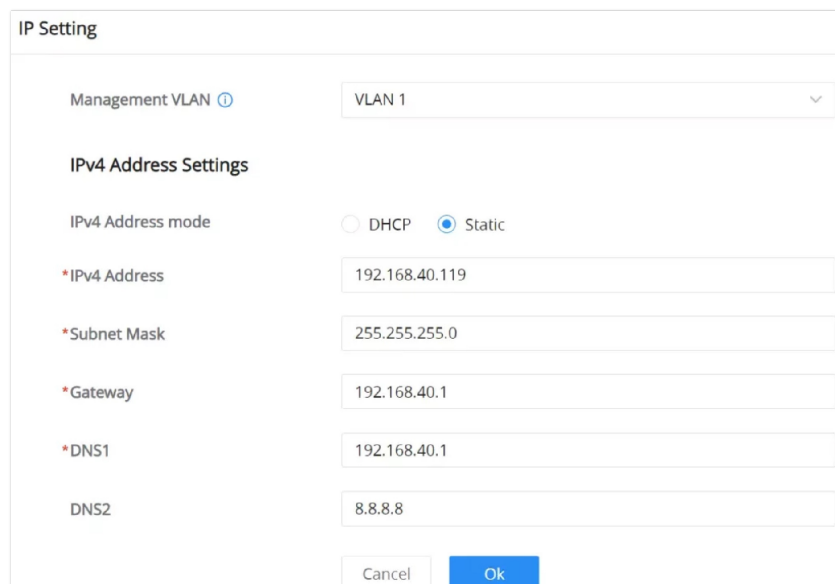

The screenshot shows the 'IP Setting' dialog box with the 'IPv4 Address Settings' section expanded. The 'Management VLAN ⓘ' dropdown is still set to 'VLAN 1'. Under 'IPv4 Address Settings', 'IPv4 Address mode' is now set to 'Static' (selected) and 'DHCP' (unselected). The fields are: '*IPv4 Address' with '192.168.40.119'; '*Subnet Mask' with '255.255.255.0'; '*Gateway' with '192.168.40.1'; '*DNS1' with '192.168.40.1'; and 'DNS2' with '8.8.8.8'. 'Cancel' and 'Ok' buttons are at the bottom.

IP Setting IPv4 Address Settings

Field Name	Description
Management VLAN	Selects the VLAN used to access the management interface. Only ports in this VLAN can access the web UI. <i>Note: Management VLAN is only valid for 802.1Q VLAN, default VLAN1, that is, only ports under VLAN1 can access the Web page.</i>
IPv4 Address Mode	Choose between automatic (DHCP) or manual (Static) IP configuration.
Automatically Get DNS	Enables automatic DNS retrieval from the DHCP server when set to DHCP mode. When disabled you can manually configure DNS1 and DNS2.
DNS1	Primary DNS server address. <i>Note: This field is available in both DHCP and Static modes when the Automatically Get DNS option is disabled.</i>
DNS2	Secondary DNS server address (optional). <i>Note: This field is available in both DHCP and Static modes when the Automatically Get DNS option is disabled.</i>
IPv4 Address	Manually enter the desired static IP address for the switch. <i>Note: This field is only available when Static mode is selected.</i>
Subnet Mask	Defines the subnet mask determining the network portion of the IP address. <i>Note: This field is only available when Static mode is selected.</i>
Gateway	Defines the gateway used for external communications. <i>Note: This field is only available when Static mode is selected.</i>

IP Setting

Management Platform

The **Management Platform** allows users to configure how the GWN771x switch connects to a management platform. The switch supports multiple management platforms, including GDMS Cloud, and GWN Manager. The management platform selection can either be automatic or manually specified by the user.

Steps to Configure the Management Platform

1. **Navigate to:** System → Management Platform.
2. **Enable DHCP Option 43:** If needed, toggle on "Allow DHCP Option 43 to Override."
3. **Select Connection Management Platform:**
 - Choose **Auto** for automatic platform selection.
 - Select **GDMS Networking, L2/L3 Manager, L2/L3 Router** based on your setup.
4. **Specify Server Address and Port** (if applicable):
 - If a specific platform is selected (e.g., L3 Manager), input the server address and port number.
5. **Save** your configuration.

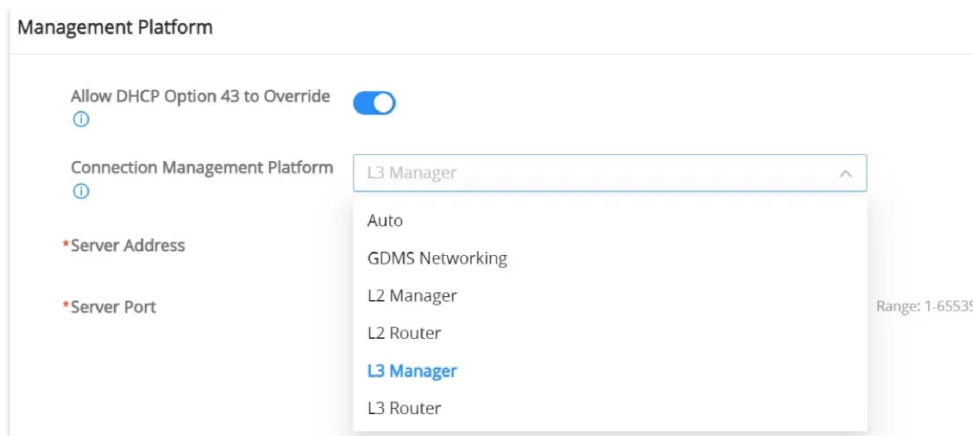

Management platform

For more details, refer to this table:

Field	Description	Notes
Allow DHCP Option 43 to Override	Enable or disable the DHCP Option 43 override.	If enabled, the server address assigned by DHCP Option 43 will be preferred.
Connection Management Platform	Select the management platform type. Options include: Auto, GDMS Networking, L2 Manager, L3 Manager	Only one platform can be connected at a time, as well as discovered and taken over by one platform. By default, it is automatic, and the priority is to GDMS Networking.
Server Address	Specify the server address of the selected management platform.	Only available when a manual platform (L3 Manager, L3 Router) is selected. Enter the IP address of the server.
Server Port	Specify the server port of the selected management platform.	Only available when a manual platform (L3 Manager, L3 Router) is selected. Enter the server port number (Range: 1-65535).

Management platform

When the switch is successfully connected to a platform (either GDMS Cloud, GWN Manager, or a Router), a corresponding **Cloud Icon** with a green check mark will appear at the top of the Web UI. This icon signifies that the switch is now integrated with the management platform, and some configurations from the platform may now be applied to the switch as shown below:

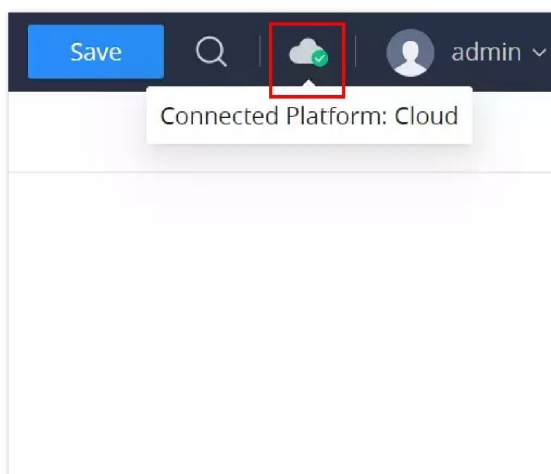

Management platform icon

SWITCHING

The switching section covers Ports and LAG (Link Aggregation Group) configurations.

Port Settings

On this page, you can configure the basic parameters for GWN771x Switch ports, like disabling or enabling the port, adding a Description, specifying the speed, Duplex mode, and Flow Control.

To configure a port, please navigate to **Switching** → **Port Settings**.

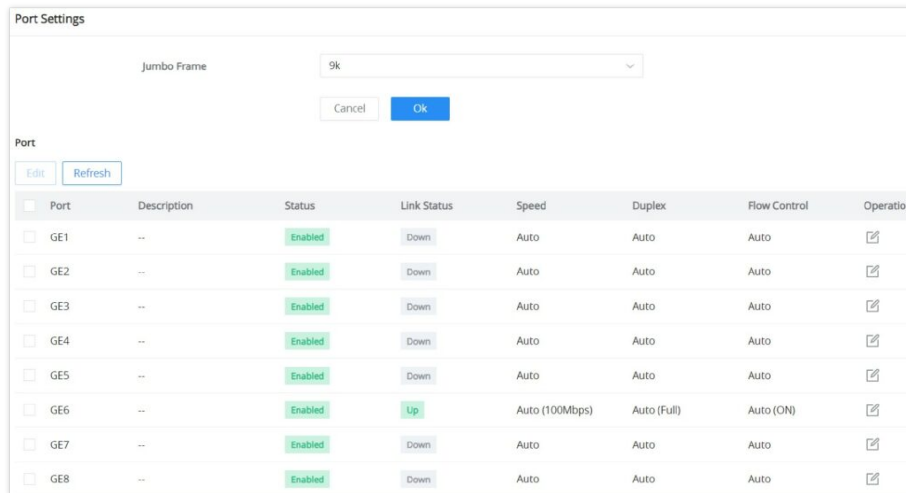

Port Settings

To configure a port, click on the "Edit" icon under the operation column.

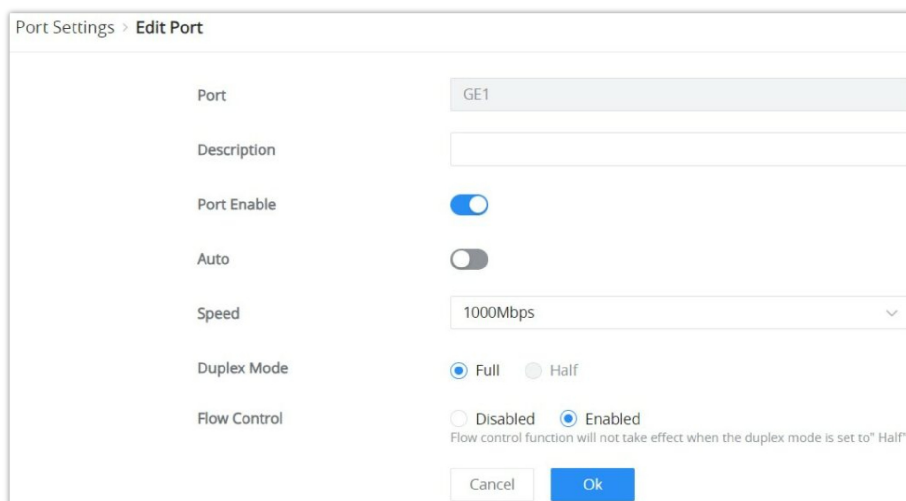

Port Settings Edit port

Port	The selected Port to be configured.
Description	It is used to configure the information description of this interface , which can be a description of usage, etc., with a maximum of 32 characters, and the characters limited to input are numbers 0-9 , letters az / AZ and special characters.
Port Enable	Set whether to enable the interface. <i>it is enabled by default.</i>
Auto	toggle ON or OFF Auto Detect, if it's ON the speed, Duplex Mode and Flow Control will be selected automatically, and if it's OFF the user can select speed, Duplex Mode and Flow Control manually.
Speed	Set the rate of the interface: <ul style="list-style-type: none"> • Ethernet port: the options are {10Mbps, 100Mbps, 1000Mbps}, The default is 1000Mbps.

	<ul style="list-style-type: none"> ● SFP+ ports: the options are {1000Mbps, 2.5Gbps, and 10Gbps}, the default is 2.5Gbps.
Duplex Mode	<p>Set the duplex mode of the interface. The options are {full-duplex, half-duplex}. <i>The default is Duplex.</i></p> <ul style="list-style-type: none"> ● Duplex: the interface send and receive data packets. ● Half-duplex: interface can only send/ receive packets.
Flow Control	<p>Set the flow control on the interface, the options are {Disabled, Enabled}. <i>The default is Enabled.</i></p> <p>After enabling it, if the local device is congested, it will send a message to the peer device to notify the peer device to temporarily stop sending packets, after receiving the message, the peer device will temporarily stop sending packets to the local and vice versa. Thus, the occurrence of packet loss is avoided.</p>

Port Settings – Edit port

Jumbo Frame

The maximum Transmission Payload or MTU is typically 1500 bytes, in case the user requires even a bigger MTU length for a specific scenario, there is an option on the GWN771x Switch to enable Jumbo Frame, the maximum Ethernet frame size ranges from 2K up to 15K. The default parameter is 9K.

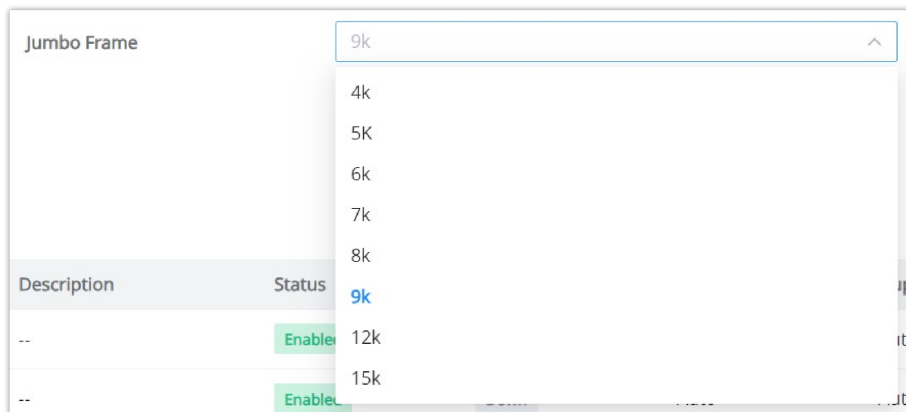

Jumbo Frame

LAG

LAG means Link Aggregation Group which groups some physical ports to make a single high-bandwidth data path. Thus it can implement traffic load sharing among the member ports in a group to enhance the connection reliability.

To configure LAG, please navigate to **Switching** → **LAG**.

GWN771x switches support up to 4 link aggregation groups as shown in the figure below:

To edit/configure a LAG, click on the **“Edit”** icon under the operation column.

LAG								
LAG	Description	Status	Link Status	Speed	Flow Control	Active Member	Inactive Member	Operation
LAG1	--	--	--	--	--	--	--	
LAG2	--	--	--	--	--	--	--	
LAG3	--	--	--	--	--	--	--	
LAG4	--	--	--	--	--	--	--	

LAG groups

LAG > Edit Group

Member Port ⓘ
Click on port to select/unselect



Description: LAG1 0-32 characters

Port Enable: Enabled

Speed: 1000Mbps

Flow Control: Disabled Enabled

Cancel Ok

Edit LAG

Member Port	Click on ports to be part of this LAG group.
Description	It is used to configure the information description for this LAG , which can be a description of usage, etc., with a maximum of 32 characters, and the characters limited to input are numbers 0-9 , letters az / AZ and special characters.
Port Enable	Set whether to enable the interface. <i>it is enabled by default.</i>
Speed	Set the rate of the interface, the options are {10Mbps, 100Mbps, 1000Mbps, 2.5Gbps} for ethernet ports and {1000Mbps, 2.5Gbps, and 10Gbps} for SFP+ ports. <i>The default is 1000Mbps.</i>
Flow Control	Set the flow control on the interface, the options are { Disabled, Enabled}. <i>The default is Enabled.</i> After enabling it, if the local device is congested, it will send a message to the peer device to notify the peer device to temporarily stop sending packets, after receiving the message, the peer device will temporarily stop sending packets to the local and vice versa. Thus, the occurrence of packet loss is avoided.

Edit LAG

MAC Address Search

The MAC address table records the correspondence between the MAC addresses of other devices learned by the switch and the interfaces, as well as information such as the VLANs to which the interfaces belong. When forwarding a packet, the device queries the MAC address table according to the destination MAC address of the packet. If the MAC address table contains an entry corresponding to the destination MAC address of the packet, it directly forwards the packet through the outbound interface in the entry. If the MAC address table does not contain an entry corresponding to the destination MAC address of the packet, the device will use broadcast mode to forward the packet on all interfaces in the VLAN to which it belongs except the receiving interface.

On this page, the user can search using the MAC address and the VLAN, if the device MAC address is found, it will be displayed on the Search Result section.

MAC Address Search

Note:

The GWN771x supports pasting a MAC address that is separated by hyphens ('-') into the MAC field. For example, you can enter the MAC address in this format: 00-0B-82-8C-4D-F8. The system will recognize and process it accordingly, eliminating the need to manually remove or replace the hyphens.

Spanning Tree

The Spanning Tree Protocol (STP) prevents network loops by creating a loop-free topology in Ethernet networks. It allows redundant paths without causing broadcast storms or multiple frame copies.

Global Settings – Spanning Tree

The **Global Settings** tab in the Spanning Tree section lets administrators configure general Spanning Tree settings and view real-time status.

To access Spanning Tree Global Settings:

1. Navigate to **Switching** → **Spanning Tree** → **Global Settings**.
2. Enable Spanning Tree by toggling the switch to **ON**.
3. Configure the following fields:

Spanning Tree Global Settings

Field Name	Description	Range
Mode	Choose between STP (Spanning Tree Protocol) and RSTP (Rapid Spanning Tree Protocol). <i>Note: RSTP is faster in convergence and more efficient in modern networks.</i>	–
Path Cost	Select either Short or Long path cost calculation.	–

	<i>Note: Short uses the IEEE 802.1D standard while Long supports larger path costs for higher-speed links.</i>	
Bridge Priority	The lower the value the higher the chance of this switch becoming the root bridge. <i>Note: Adjust this based on network topology.</i>	Range 0-61440, must be a multiple of 4096
Hello Time (s)	Defines the time interval between BPDU transmissions by the root bridge.	1 – 10 seconds
Max Aging Time (s)	Sets how long the switch will keep BPDU information before discarding it.	6 – 40 seconds
Forward Delay Time (s)	Determines how long a port spends in Listening and Learning states before transitioning to Forwarding.	4 – 30 seconds

Spanning Tree – Global Settings

This section displays the current status of the spanning tree topology. You can refresh the information by clicking the **Refresh** icon.

Status	
Bridge ID:	32768-EC:74:D7:0D:52:B9
Root Bridge ID:	32768-C0:74:AD:BA:24:FC
Root Port:	GE8
Root Path Cost:	4
Topology Change Count:	1
Latest Topology Change:	46 minutes 48 seconds

Spanning Tree Real Time Status Information

Field Name	Description
Bridge ID	The unique identifier for the current bridge (switch).
Root Bridge ID	The identifier for the root bridge in the spanning tree topology.
Root Port	The port used to reach the root bridge.
Root Path Cost	The cost of the path to the root bridge from this switch.
Topology Change Count	The number of times the network topology has changed.
Latest Topology Change	The time since the last topology change.

Spanning Tree – Real-Time Status Information

Port Settings – Spanning Tree

The **Port Settings** tab allows configuration of Spanning Tree on a per-port basis, enabling administrators to control port behavior, priority, path cost, and monitor port status.

Spanning Tree									
Global Settings		Port Settings							
Edit									
<input checked="" type="checkbox"/>	Port	Status	Priority	Path Cost	Edge Port	Point-to-Point	Port Status	Port Role	Operation
<input checked="" type="checkbox"/>	GE1 (LAG1)	Enabled	128	65535	Disabled	Auto	Disabled	Disabled Port	
<input checked="" type="checkbox"/>	GE2 (LAG1)	Enabled	128	65535	Disabled	Auto	Disabled	Disabled Port	
<input checked="" type="checkbox"/>	GE3	Disabled	128	65535	Disabled	Auto	Disabled	Disabled Port	
<input checked="" type="checkbox"/>	GE4	Enabled	128	65535	Disabled	Auto	Disabled	Disabled Port	
<input checked="" type="checkbox"/>	GE5	Disabled	128	65535	Disabled	Auto	Disabled	Disabled Port	
<input checked="" type="checkbox"/>	GE6	Enabled	128	65535	Disabled	Auto	Disabled	Disabled Port	
<input checked="" type="checkbox"/>	GE7	Enabled	128	65535	Disabled	Auto	Disabled	Disabled Port	
<input checked="" type="checkbox"/>	GE8	Enabled	128	4	Disabled	Auto	Forwarding	Root Port	

Spanning Tree Port Settings

To configure Spanning Tree on specific ports:

1. Navigate to **Switching** → **Spanning Tree** → **Port Settings**.
2. Select the port you wish to configure and click **Edit**.
3. Configure the following fields:

Port Settings > **Edit**

Port:

Spanning Tree

*Priority: Range: 0-240, must be a multiple of 16

*Path Cost Range: 0-65535

Edge Port: Disabled Enabled Auto

Point-to-Point: Disabled Enabled Auto

Port Status: Forwarding

Designated Bridge ID: 32768.CO:74:AD:BA:24:FC

Designated Port ID: 128-4

Path Cost: 4

Operational Edge: Disabled

Operational Point-to-Point: Disabled

Spanning Tree Port Settings

Field Name	Description	Range
Port	The specific port being configured for Spanning Tree Protocol.	—
Spanning Tree	Enables or disables Spanning Tree for the selected port. <i>Note: If the port is self-looping, the port will be automatically shut down, and the port needs to be manually enabled again.</i>	—
Priority	Assigns priority to the port. Lower values make this port more likely to become the root port in case of a tie.	0 – 240 (multiples of 16)
Path Cost	Defines the cost of using this port to reach the root bridge. Lower costs indicate more desirable paths. The default value is 0 meaning the switch automatically calculates based on link speed.	Range: 0-65535
Edge Port	Enable if the port is connected to an end device and is not expected to receive BPDUs. Auto will detect if the port should behave as an edge port.	—

Point-to-Point	Specifies whether the port operates as a point-to-point link. Auto allows detection of the link type.	–
-----------------------	---	---

Spanning Tree – Port Settings

Port Status

This section provides real-time information about the selected port's spanning tree status.

Port Status:	Forwarding
Designated Bridge ID:	32768-C0:74:AD:BA:24:FC
Designated Port ID:	128-4
Path Cost:	4
Operational Edge:	Disabled
Operational Point-to-Point:	Disabled

Spanning Tree Port Status

Field Name	Description
Port Status	Indicates whether the port is currently active
Designated Bridge ID	The bridge ID of the designated bridge for the port.
Designated Port ID	The ID of the port designated for this spanning tree configuration.
Path Cost (Status)	Displays the actual path cost currently being used by the port.
Operational Edge	Shows whether the port is operating as an edge port.
Operational Point-to-Point	Displays whether the port is operating as a point-to-point link.

Spanning Tree – Port Status

VLAN

A virtual local area network, virtual LAN or VLAN, is a group of hosts with a common set of requirements that communicate as if they were attached to the same broadcast domain, regardless of their physical location. A VLAN has the same attributes as a physical local area network (LAN), but it allows for end stations to be grouped even if they are not located on the same network switch. VLAN membership can be configured through software instead of physically relocating devices or connections.

Port VLAN

On this page, the user can select which VLANs (a preset from 1 to 8) can be allowed on GWN771x ports. This is a simplified way to manage VLAN from 1 to 8. To have more flexibility and control, please enable 802.1Q VLAN and Port VLAN will be disabled automatically.

First Enable Port VLAN as shown below:

When Port VLAN is enabled, 802.1Q VLAN will be automatically disabled and the configured information will be lost.

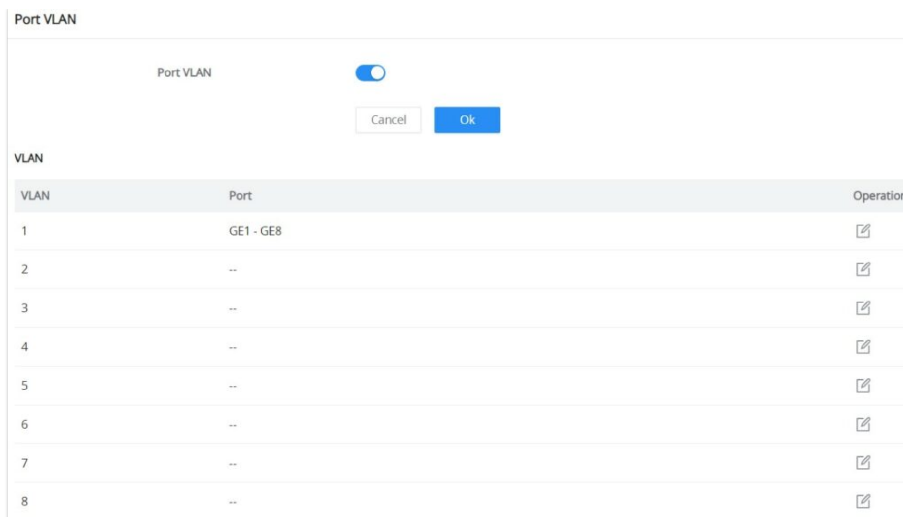

Port VLAN

Click the **“Edit”** icon under the Operation column to edit a VLAN, then select which ports this VLAN will be allowed on.

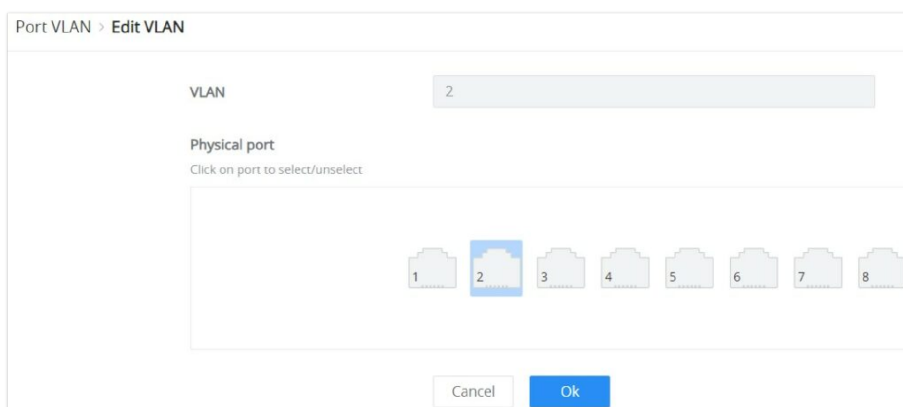

Port VLAN Edit VLAN

802.1Q VLAN

For more flexibility and control over VLAN configuration, the user can enable 802.1Q VLAN, and in this case the user is not only restricted to VLANs from 1 to 8.

Click on the **“Add”** button to add a VLAN, as shown below:

When 802.1Q VLAN is enabled, Port VLAN will be automatically disabled and the configured information will be lost.

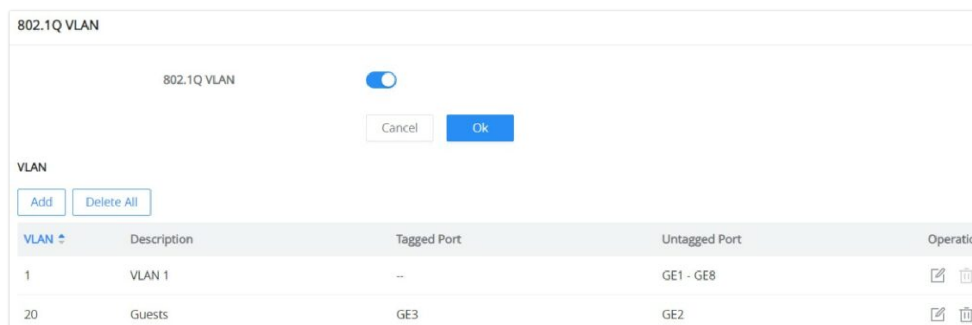

8021Q VLAN

Deletion safeguards (Delete All)

Clicking **Delete All** removes only user-created VLANs. The following VLANs are protected and are not deleted: **VLAN 1**, the **Management VLAN**, and the **Voice VLAN**. The UI displays:

“VLAN 1, Management VLAN, and Voice VLAN cannot be deleted.”

Note: Protection follows the current IDs you’ve configured. If the Management VLAN or Voice VLAN equals VLAN 1, it remains protected as well. If Voice VLAN is disabled, only VLAN 1 and the Management VLAN are protected.

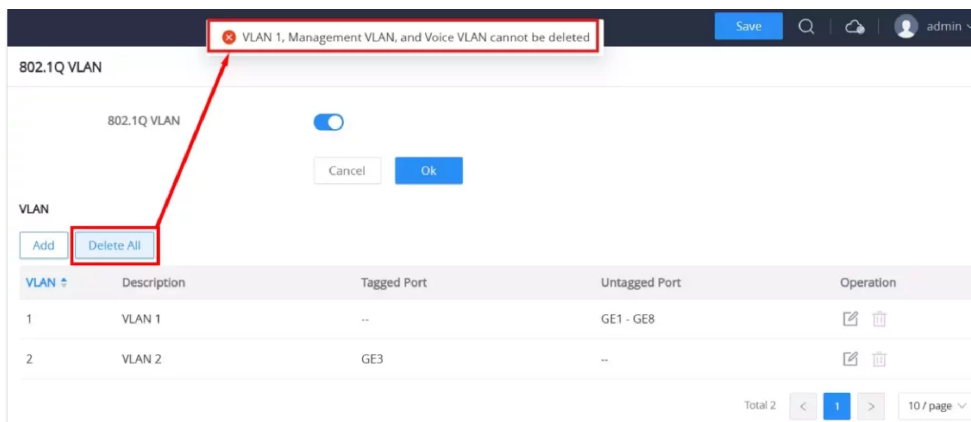

Delete All

On this screen, the user can configure the VLAN:

- o **VLAN:** specify the VLAN ID (Range 2-4094).
- o **Description:** enter a description for the VLAN.
- o **Member Type:** a shortcut to untag/tag or remove all members.
- o **Physical port:** select the tagged/untagged ports accordingly.

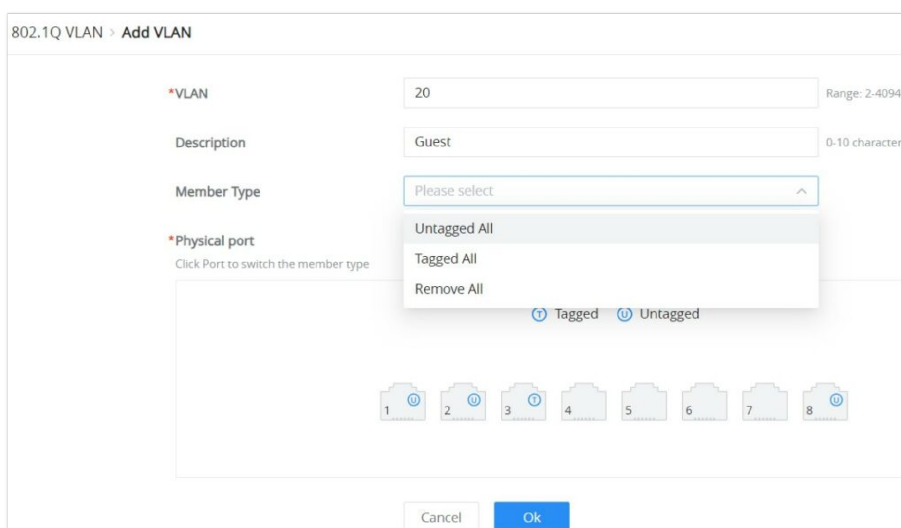

8021Q VLAN addedit VLAN

802.1Q PVID Settings

If **802.1Q VLAN** is enabled, this page lets you assign the **PVID (Port VLAN ID)** on each port and control whether the port operates in **VLAN Transparent** mode.

Port	PVID	VLAN Transparent	Operation
<input checked="" type="checkbox"/> GE1	1	Enabled	
<input checked="" type="checkbox"/> GE2	1	Enabled	
<input checked="" type="checkbox"/> GE3	1	Enabled	
<input type="checkbox"/> GE4	1	Disabled	
<input type="checkbox"/> GE5	1	Disabled	
<input type="checkbox"/> GE6	1	Disabled	
<input type="checkbox"/> GE7	1	Disabled	
<input type="checkbox"/> GE8	1	Disabled	

8021Q PVID Settings

Field descriptions

- **Port:** Physical interface identifier.
- **PVID:** VLAN ID used to classify **untagged** ingress frames on the port. Egress tagging is determined by the port's membership on the **802.1Q VLAN** page.
- **VLAN Transparent:** Per-port switch that determines how **tagged** frames are handled.
 - **Disabled:** The port enforces the local 802.1Q VLAN table. Frames are forwarded only for VLANs where the port is a member (Tagged or Untagged).
 - **Enabled:** The port bypasses the local 802.1Q VLAN table and directly passes all VLAN-tagged packets. The on-screen help states:
"Once enabled, the port will no longer check the local 802.1Q VLAN table entries and will directly pass through all VLAN packets."
- **Operation:** Opens the **Edit Port** dialog.

Configure PVID and VLAN Transparent

1. Go to **VLAN** → **802.1Q PVID Settings**.
2. In the table, click **Edit** for the target port.

The screenshot shows a dialog box titled "Edit Port" with a close button (X) in the top right corner. It contains three main sections: "Port" with a text input field containing "GE1"; "PVID" with a dropdown menu showing "1" and a downward arrow; and "VLAN Transparent" with an information icon (i) and a blue toggle switch that is currently turned on. At the bottom of the dialog are two buttons: "Cancel" and "OK".

8021Q PVID Settings edit port

3. Set **PVID** to the VLAN ID that should classify **untagged** ingress traffic on that port.
4. Set **VLAN Transparent** as required:
 - **Enabled** to pass through tagged frames without checking local VLAN membership.
 - **Disabled** to enforce the VLAN membership defined on **VLAN** → **802.1Q VLAN**.
5. Click **OK**, then **Save**.

Notes:

- **Scope:** *VLAN Transparent affects handling of **tagged** frames on that port. **Untagged** frames are still classified by the port's **PVID**.*
- **Membership:** *Enabling VLAN Transparent does not modify the VLAN membership table; it simply bypasses membership checks for tagged traffic on that port.*
- **Use cases:** *Inline/uplink ports that must relay existing VLAN tags as-is. For access ports, leave VLAN Transparent **Disabled** so traffic is classified and enforced per the VLAN table.*
- **Mode dependency:** *This page applies only when **802.1Q VLAN** is enabled. It does not apply in **Port VLAN** mode.*

Voice VLAN

This feature allows network administrators to prioritize voice traffic, improving VoIP call quality and ensuring efficient bandwidth usage.

Global Settings – Voice VLAN

This section allows administrators to enable and configure the Voice VLAN feature globally.

Note:

802.1Q VLAN must be enabled first before configuring Voice VLAN, as Voice VLAN relies on the VLAN tags for traffic segregation.

Fields & Options:

- **Voice VLAN:** Dropdown menu with the following options:
 - **Disabled:** Turns off the Voice VLAN feature.
 - **Tagged OUI:** This option assigns a specific VLAN ID to tagged packets from voice devices based on their Organizationally Unique Identifier (OUI). Devices that have their traffic tagged according to their OUI will be assigned to this VLAN.
 - **Untagged OUI:** This option assigns a VLAN ID to untagged packets from recognized voice devices. Devices without VLAN tagging but matching an OUI in the system will be assigned to the Voice VLAN. This is particularly useful in scenarios where VoIP phones or softphones do not support VLAN tagging but need to be assigned to the designated Voice VLAN for quality of service (QoS) prioritization.
- **Voice VLAN ID:**
 - Specifies the VLAN ID that will be used for voice traffic.
 - Required if “Tagged OUI” or “Untagged OUI” is selected.
- **CoS/802.1p Priority:**
 - Defines the priority level for Voice VLAN traffic (range: 0-7). Higher values indicate higher priority for voice packets. Proper CoS/802.1p priority settings enhance VoIP performance by ensuring voice packets are transmitted with higher priority.

Port	Status	Mode	Operation
<input checked="" type="checkbox"/> GE1	Enabled	Manual	
<input checked="" type="checkbox"/> GE2	Enabled	Auto	

Voice VLAN Global Settings

Port Settings

Configuring specific ports for Voice VLAN ensures that only designated ports handle voice traffic, optimizing network performance and preventing unnecessary congestion on non-voice ports.

This section configures Voice VLAN on specific ports.

Steps to configure:

1. Click **Edit** to modify port settings.
2. Select the ports to apply Voice VLAN.
3. Enable the **Voice VLAN** toggle.
4. Select a **Mode**:
 - **Manual:** Retains manual ingress filtering rules.
 - **Auto:** Disables ingress filtering for recognized voice packets, allowing automatic handling.

5. Click **OK** to save.

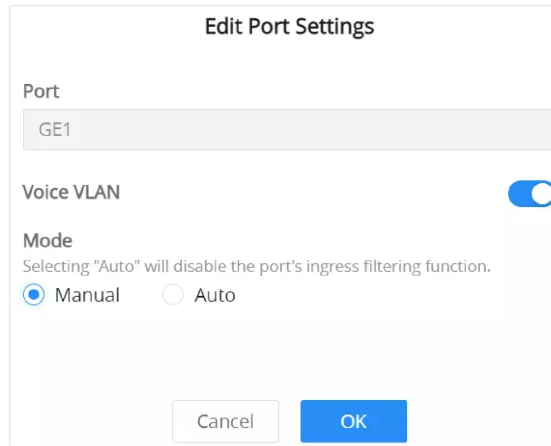

The 'Edit Port Settings' dialog box shows the port name 'GE1'. The 'Voice VLAN' toggle is turned on. Under 'Mode', 'Manual' is selected with a radio button, and 'Auto' is unselected. A note states: 'Selecting "Auto" will disable the port's ingress filtering function.' At the bottom are 'Cancel' and 'OK' buttons.

Voice VLAN Global Settings Port Settings

OUI Settings

Managing OUIs is crucial for ensuring that only authorized voice devices are recognized and assigned to the Voice VLAN. This helps improve network efficiency by reducing misclassified traffic and enhances security by preventing unauthorized devices from accessing the designated VLAN.

This section allows customization of Organizationally Unique Identifiers (OUIs) used to recognize voice devices.

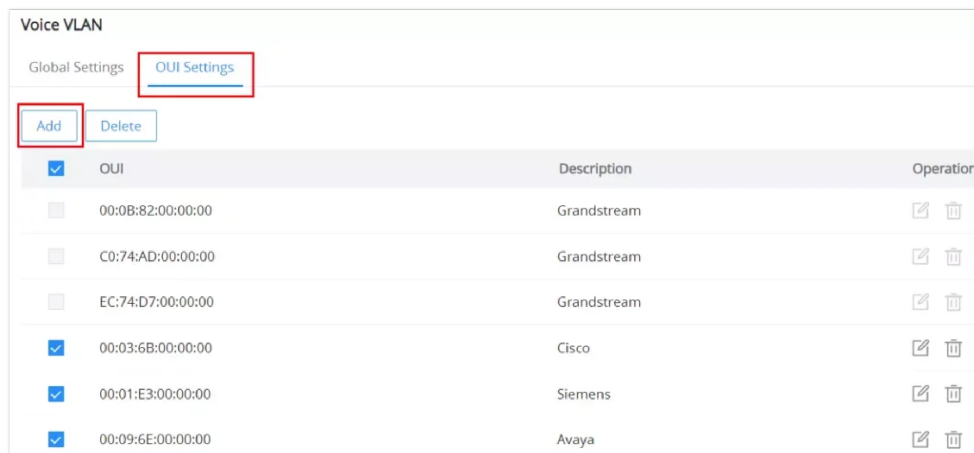

The 'Voice VLAN OUI Settings' table lists OUIs with their descriptions and operation icons. The 'Add' button is highlighted with a red box. The 'OUI Settings' link is also highlighted with a red box.

OUI	Description	Operation
<input type="checkbox"/> 00:0B:82:00:00:00	Grandstream	
<input type="checkbox"/> C0:74:AD:00:00:00	Grandstream	
<input type="checkbox"/> EC:74:D7:00:00:00	Grandstream	
<input checked="" type="checkbox"/> 00:03:6B:00:00:00	Cisco	
<input checked="" type="checkbox"/> 00:01:E3:00:00:00	Siemens	
<input checked="" type="checkbox"/> 00:09:6E:00:00:00	Avaya	

Voice VLAN OUI

Options Available:

- **Add New OUI:**
 - Allows manual entry of an OUI address for voice devices.
 - Choose **Custom** to enter an OUI manually or select a predefined OUI from the dropdown list.
 - The OUI address consists of the first three octets of a MAC address (e.g., **00:B8:82**).
 - Optionally, enter a **Description** (up to 32 characters) to label the OUI.
 - Click **OK** to save.

Add OUI

OUI

*OUI Address
 : : : : :

Description
 0-32 characters

Voice VLAN Add OUI

IGMP SNOOPING

The GWN771x switches support IGMP snooping, which is an IPv4 Layer 2 multicast protocol that optimizes the handling of multicast traffic in a network by intelligently forwarding traffic only to the ports where interested hosts are located, based on the monitoring of IGMP messages.

On the **Global Settings** tab, the users can enable the IGMP Snooping feature by toggling ON the feature, and for Unknown Multicast Packet will be either dropped or flooded as shown below:

IGMP Snooping

[Global Settings](#) [Dynamic Router Port](#)

IGMP Snooping

Unknown Multicast Packet

Report Suppression

Fast Leave

Multicast Address

VLAN	Multicast Address	Member Port
 No Data		

IGMP Snooping Global Settings

IGMP snooping dynamically identifies router ports by monitoring IGMP General Query messages and optimizes the forwarding of multicast traffic to those ports for efficient use of network bandwidth.

The **Dynamic Router Port** tab displays all the discovered dynamic router ports, the users can click on the **Refresh** button to refresh the list.

IGMP Snooping

[Global Settings](#) [Dynamic Router Port](#)

VLAN	Dynamic Router Port
 No Data	

QoS

The popularity of the network and the diversification of services have led to a surge in Internet traffic, resulting in network congestion, increased forwarding delay, and even packet loss in severe cases, resulting in reduced service quality or even unavailability. Therefore, to carry out these real-time services on the network, it is necessary to solve the problem of network congestion. The best way is to increase the bandwidth of the network, but considering the cost of operation and maintenance, this is not realistic. The most effective solution is to apply "Guaranteed" policies to govern network traffic. QoS technology is developed under this background. QoS is quality of service, and its purpose is to provide end-to-end service quality assurance for various business needs. QoS is a tool for effectively utilizing network resources. It allows different traffic flows to compete for network resources unequally. Voice, video, and important data applications can be prioritized in network equipment.

QoS Basic Settings

On this page, the user can edit the port priority for each port, supported modes are:

- Port-Based
- 802.1P-Based
- DSCP-Based

Please navigate to **QoS** → **QoS Basic Settings** page:

QoS Basic Settings

QoS Mode: Port-Based 802.1P-Based DSCP-Based

Buttons: Cancel, Ok

Port Priority

Edit

Port	Priority	Operation
<input checked="" type="checkbox"/> GE1	0	
<input checked="" type="checkbox"/> GE2	0	
<input type="checkbox"/> GE3	0	
<input type="checkbox"/> GE4	0	
<input type="checkbox"/> GE5	0	
<input type="checkbox"/> GE6	0	
<input type="checkbox"/> GE7	0	
<input type="checkbox"/> GE8	0	

QoS Basic Settings

Select one or multiple ports, then click on the "Edit" button to modify the ports' priority. The priority range is from 0 to 7, a larger value indicates a higher priority, and value 0 is the default value.

Edit

Port

GE1

* Priority

Range 0-7. A larger value indicates a higher priority

0

Buttons: Cancel, OK

QoS Basic Settings Edit Port Priority

Priority Mapping

Priority mapping is used to realize the conversion between the QoS priority carried in the packet and the internal priority of the device (also known as the local priority, which is the priority used by the device to differentiate the service level of the packet) so that the device provides the Differentiated QoS service quality. Users can use different QoS priority fields in different networks according to network planning.

- o **802.1p Mapping**

On this tab, the user can map between 802.1p and CoS (Class of Service) where 0 is the lowest priority and 7 is the highest priority for 802.1p, and by default, CoS is set to be the same (it's recommended to keep it by default only if necessary or a specific network requires it).

802.1p	CoS
0	0
1	1
2	2
3	3
4	4
5	5
6	6
7	7

Priority Mapping 8021p Mapping

- o **DSCP Mapping**

On this tab, the user can map between CoS and DSCP (Differentiated Services Code Point), in this case, 802.1p and CoS mapping must be configured first. (it's recommended to keep the default settings to keep the consistency between all switches only if it's necessary or the network requires it)

DSCP	CoS	DSCP	CoS	DSCP	CoS	DSCP	CoS	DSCP	CoS	DSCP	CoS	DSCP	CoS	DSCP	CoS
0[CS0]	0	8[CS1]	1	16[CS2]	2	24[CS3]	3	32[CS4]	4	40[CS5]	5	48[CS6]	6	56[CS7]	7
1	0	9	1	17	2	25	3	33	4	41	5	49	6	57	7
2	0	10[AF11]	1	18[AF21]	2	26[AF31]	3	34[AF41]	4	42	5	50	6	58	7
3	0	11	1	19	2	27	3	35	4	43	5	51	6	59	7
4	0	12[AF12]	1	20[AF22]	2	28[AF32]	3	36[AF42]	4	44	5	52	6	60	7
5	0	13	1	21	2	29	3	37	4	45	5	53	6	61	7
6	0	14[AF13]	1	22[AF23]	2	30[AF33]	3	38[AF43]	4	46[EF]	5	54	6	62	7
7	0	15	1	23	2	31	3	39	4	47	5	55	6	63	7

Priority Mapping DSCP Mapping

Note:

Mapping can be configured based on the specific needs and requirements of the network, and it's important to ensure consistency across all network devices for effective Quality of Service (QoS) management.

Queue Scheduling

When congestion occurs in the network, the device will determine the processing order of forwarding packets according to the specified scheduling policy, so that high-priority packets are preferentially scheduled.

Queue scheduling algorithm: queue scheduling according to the switch interface.

- **Strict priority (SP) scheduling:** The flow with the highest priority is served first, and the flow with the second highest priority is served until there is no flow at that priority. Each interface of the switch supports 8 queues (queues 0-7), queue 7 is the highest priority queue, and queue 0 is the lowest priority queue. **Disadvantage:** When congestion occurs, if there are packets in the high-priority queue for a long time, the packets in the low-priority queue cannot be scheduled, and data cannot be transmitted.
- **Weighted Round Robin (WRR) scheduling:** each priority queue is allocated a certain bandwidth, and provides services for each priority queue according to the priority from high to low. When the high-priority queue has used up all the allocated bandwidth, it is automatically switched to the next priority queue to serve it.
- **Weighted Fair Queuing (WFQ) scheduling:** Based on ensuring fairness (bandwidth, delay) as much as possible, priority considerations are added, so that high-priority packets have more opportunities for priority scheduling than low-priority packets. WFQ can automatically classify flows by their "session" information (protocol type, source and destination IP addresses, source, and destination TCP or UDP ports, priority bits in the ToS field, etc.) Place each flow evenly into different queues, thus balancing the latency of the individual flows as a whole. When dequeuing, WFQ allocates the bandwidth that each flow should occupy at the egress according to the flow priority (Precedence). The smaller the priority value is, the less bandwidth is obtained; otherwise, the more bandwidth is obtained.

Select one or multiple ports, then click on the "Edit" button to modify the ports **Queuing Algorithm**. The default algorithm is set to Strict Priority (SP).

Queue Scheduling											
<input type="button" value="Edit"/>											
Port	Queuing Algorithm	Weight								Operation	
		0	1	2	3	4	5	6	7		
<input checked="" type="checkbox"/>	GE1	Strict Priority (SP)	--	--	--	--	--	--	--	--	
<input checked="" type="checkbox"/>	GE2	Strict Priority (SP)	--	--	--	--	--	--	--	--	
<input type="checkbox"/>	GE3	Strict Priority (SP)	--	--	--	--	--	--	--	--	
<input type="checkbox"/>	GE4	Strict Priority (SP)	--	--	--	--	--	--	--	--	
<input type="checkbox"/>	GE5	Strict Priority (SP)	--	--	--	--	--	--	--	--	
<input type="checkbox"/>	GE6	Strict Priority (SP)	--	--	--	--	--	--	--	--	
<input type="checkbox"/>	GE7	Strict Priority (SP)	--	--	--	--	--	--	--	--	
<input type="checkbox"/>	GE8	Strict Priority (SP)	--	--	--	--	--	--	--	--	

Queue Scheduling

If **Weighted Round Robin (WRR)** or **Weighted Fair Queuing (WFQ)** is selected, the Weight option can be configured accordingly, the higher the Weight the higher the traffic priority.

Note:

- **Weighted Round Robin (WRR):** Scheduled based on weighted round robin. The weight of each queue is set in packets.
- **Weighted Fair Queuing (WFQ):** Schedule according to WFQ. The weight of each queue is set by bytes.

Queue Scheduling > **Edit**

Port: GE1

Queuing Algorithm: Strict Priority (SP)

Queue ID	Weight
0	--
1	--
2	--
3	--
4	--

Cancel Ok

Queue Scheduling Edit

Rate Limit

Interface rate limit can limit the total rate of all packets sent or received on an interface. The interface rate limit also uses the token bucket to control the flow. If an interface rate limit is configured on an interface of the device, all packets sent through this interface must first be processed through the token bucket of the interface rate limiter. If there are enough tokens in the token bucket, the packet can be sent; otherwise, the packet will be discarded or cached.

To configure Rate Limit, please navigate to **QoS** → **Rate Limit**, then select one or multiple ports, click on the **"Edit"** button to edit the port(s).

Rate Limit

Edit

Port	Ingress	Ingress CIR (Kbps)	Egress	Egress CIR (Kbps)	Operation
<input checked="" type="checkbox"/> GE1	Disabled	--	Disabled	--	
<input type="checkbox"/> GE2	Disabled	--	Disabled	--	
<input type="checkbox"/> GE3	Disabled	--	Disabled	--	
<input type="checkbox"/> GE4	Disabled	--	Disabled	--	
<input type="checkbox"/> GE5	Disabled	--	Disabled	--	
<input type="checkbox"/> GE6	Disabled	--	Disabled	--	
<input type="checkbox"/> GE7	Disabled	--	Disabled	--	
<input type="checkbox"/> GE8	Disabled	--	Disabled	--	

Rate Limit page

Enable the **Ingress** (incoming traffic to the switch) and then set the rate limit (in Kbps), and then enable Egress (**outgoing traffic**) and set the rate limit (in Kbps).

Note:

CIR is the average rate at which traffic can pass. If both Ingress and Storm Control are enabled, the smaller value between them takes effect.

Rate Limit > Edit

Port: GE1

Ingress:

*Ingress CIR (Kbps): 1000000

Egress:

*Egress CIR (Kbps): 1000000

Cancel Ok

Rate Limit Edit port

Security

Storm Control

The GWN771x switches support a storm control feature that prevents broadcast, unknown multicast, or unknown unicast by monitoring and limiting excessive traffic on a port. It helps prevent network congestion and performance problems caused by an overwhelming amount of packets. Thresholds are set to limit traffic when defined limits are exceeded.

Navigate to **QoS** → **Storm Control**, then select the unit that Storm Control will use:

- o **Kbps**
- o **pps** (packet per second)

Note:

- o When the unit is pps, Ingress enabled at the port may cause errors in the storm control threshold.
- o **IFG** (Inter-Frame Gap) is the duration between the transmissions of two consecutive frames. IFG helps in preventing collisions on the network.

Storm Control

Unit: kbps

IFG: Include Exclude

Cancel Ok

Port

Edit

Port	Status	Broadcast	Broadcast Threshold	Unknown Multicast	Unknown Multicast Threshold	Unknown Unicast	Operation
<input checked="" type="checkbox"/> GE1	Disabled	Disabled	--	Disabled	--	Disabled	
<input type="checkbox"/> GE2	Disabled	Disabled	--	Disabled	--	Disabled	
<input type="checkbox"/> GE3	Disabled	Disabled	--	Disabled	--	Disabled	
<input type="checkbox"/> GE4	Disabled	Disabled	--	Disabled	--	Disabled	
<input type="checkbox"/> GE5	Disabled	Disabled	--	Disabled	--	Disabled	
<input type="checkbox"/> GE6	Disabled	Disabled	--	Disabled	--	Disabled	
<input type="checkbox"/> GE7	Disabled	Disabled	--	Disabled	--	Disabled	

Storm Control main page

Select one or multiple ports then click on the "Edit" button or icon under column operation to edit the selected port(s). Please refer to the figure and table below:

Storm Control > Edit

Port: GE1

Storm Control:

Broadcast: *Threshold (Kbps): 64 The valid range is 1-1000000, and it is automatically converted to an approximation of the port fit.

Unknown Multicast: *Threshold (Kbps): 64 The valid range is 1-1000000, and it is automatically converted to an approximation of the port fit.

Unknown Unicast: *Threshold (Kbps): 64 The valid range is 1-1000000, and it is automatically converted to an approximation of the port fit.

Cancel Ok

Storm Control Edit a port

Unit	<p>Select Unit:</p> <ul style="list-style-type: none"> ● kbps: Storm control rate will be calculated by octet-based. ● pps: Storm control rate will be calculated by packet-based.
IFG	<p>Select IFG (Inter Frame Gap):</p> <ul style="list-style-type: none"> ● Excluded: Exclude IFG when count ingress storm control rate. ● Included: Include IFG when count ingress storm control rate.
Storm Control → Edit	
Port	Displays the selected port.
Storm Control	Select whether to enable Storm Control on the selected port or not.
Broadcast	<p>Set whether to enable the storm threshold setting for broadcast packets. If Enabled Please enter a Treshhold (Kbps).</p> <p><i>Note: The valid range is 1-1000000, and it is automatically converted to an approximation of the port fit.</i></p>
Unknown Multicast	<p>Set whether to enable the storm threshold setting for the Unknown Multicast packets If Enabled Please enter a Treshhold (Kbps).</p> <p><i>Note: The valid range is 1-1000000, and it is automatically converted to an approximation of the port fit.</i></p>
Unknown Unicast	<p>Set whether to enable the storm threshold setting for the Unknown Unicast packets. If Enabled Please enter a Treshhold (Kbps).</p> <p><i>Note: The valid range is 1-1000000, and it is automatically converted to an approximation of the port fit.</i></p>

Storm Control

DHCP Snooping

DHCP Snooping is a security feature that protects against rogue DHCP servers. It allows network administrators to specify trusted and untrusted ports, ensuring that only legitimate DHCP servers can provide IP addresses. Untrusted ports will drop DHCP server responses from unauthorized servers, while trusted ports will allow traffic from legitimate DHCP servers.

To enable DHCP Snooping:

1. **Log into the Web UI** of your GWN771x switch.
2. **Navigate to:**
 - **Security → DHCP Snooping**
3. **Enable DHCP Snooping** globally by toggling the switch at the top of the page.

Once enabled, DHCP Snooping will monitor and filter DHCP traffic on all interfaces.

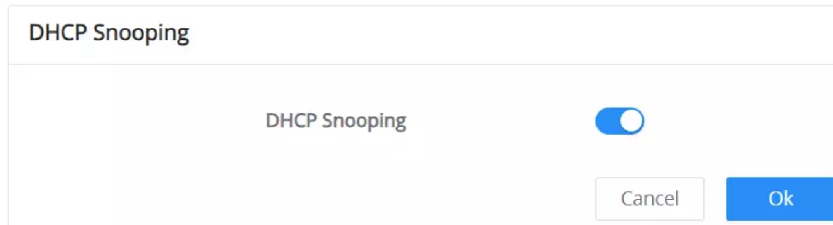

Enable DHCP Snooping

DHCP Snooping Port Settings

Configure the trusted/untrusted status of each port, and whether DHCP Option 82 is enabled, to help with tracking and security.

Port-Specific Settings: You can configure DHCP Snooping on individual ports.

- Click **Edit** next to the port you want to configure.
- The following fields can be adjusted:

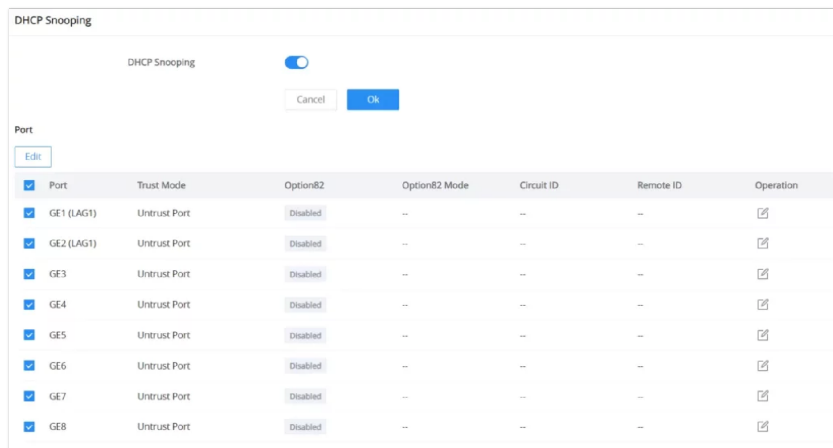

DHCP Snooping Port Settings

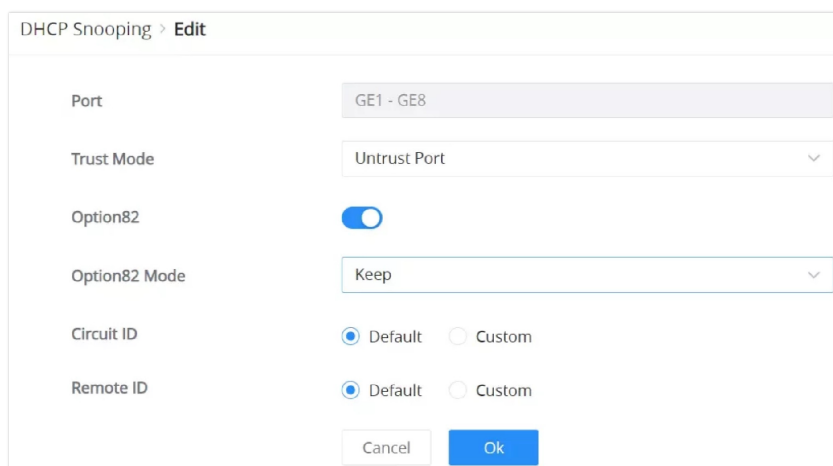

DHCP Snooping Edit port

Field	Description	Note
Port	The interface where DHCP Snooping is configured.	Available for all ports.
Trust Mode	Specifies whether the port is trusted or untrusted.	<i>Note: Trusted ports accept DHCP packets from legitimate DHCP servers and untrusted ports drop DHCP server packets.</i>

Option 82	Enables DHCP Option 82	which is used to add additional information (Relay Agent Information) in DHCP requests.
Option 82 Mode	Determines how the relay information should be handled.	Options are: Keep, Drop and Replace.
Circuit ID	The circuit ID that identifies the connection. Can be set to 'Default' or 'Custom'.	Only available when 'Option 82' is enabled.
Remote ID	The remote ID that provides information about the remote connection. Can be set to 'Default' or 'Custom'.	Only available when 'Option 82' is enabled.

DHCP Snooping Edit port

POE

Power Over Ethernet (PoE) refers to supplying power over an Ethernet network, also known as a local area network-based power supply system PoL or Active Ethernet.

Usually, the terminal devices of the access point need to use a DC power supply, but due to insufficient wiring, these devices need unified power management. At this time, the switch interface provides the power supply function, which can solve the above problems and realize the precise control of the port PoE power supply.

Power Supply Info

This page Displays the Power Supply Info like the number of PoE, Total, Remaining PoE Power, etc, and even the Supply Voltage.

Power Supply Info	
Refresh	
Global	
PoE Port Number:	4
Total Power Input:	65.00 W
Total PSE Power:	60.00 W
4Pair Remaining Power:	0.00 W
PSE Power Consumption:	0.00 W
PSE Remaining Power:	60.00 W
Chip 1	
Work Status:	On
Supply Voltage:	52.65 V

Power Supply Info

Power Supply Setting

On this page, the user can configure the total power input and configure PoE on each port that supports PoE. e.g, on the GWN7711P switch model, the ports 1-4 support PoE/PoE+.

Total Power Input: Configure proper power based on the selected power supply.

For instance, if the user sets the Total Power Input to 15 watts, this amount of power is insufficient to power both the switch and more than two access points simultaneously using PoE. Consequently, the power shortfall may cause the devices to reboot repeatedly due to the inadequate power supply.

Port	Power Status	Power Supply Standard	Power Supply Mode	Power Supply Priority	Max Power Supply(W)	Current (mA)	Current Power(W)	PD Class	Temperature(°C)	Operation
GE1	Not powered	802.3af/at	Auto	Low	30.00	--	--	--	37.00	
GE2	Not powered	802.3af/at	Auto	Low	30.00	--	--	--	35.00	
GE3	Not powered	802.3af/at	Auto	Low	30.00	--	--	--	36.00	
GE4	Not powered	802.3af/at	Auto	Low	30.00	--	--	--	36.00	

Total Power Input

Alert:

- o Please configure the appropriate power according to the power supply selected. When the configured power exceeds the actual power, it may cause the device to restart repeatedly!
- o On GWN7711P, when the switch boots on a **12V** power supply, the **Total Power Input** defaults to **120W**.

Confirm to modify the total input power?

1. Please confirm the total power input is within the specifications of the power supply.
2. Modifying the total power supply may cause the PD device to be powered off and restarted.

I am aware of the risks.

Total Power Input prompt

To reset the PSE, click on the "PSE Reset" button as shown below:

Port	Power Status	Power Supply Standard	Power Supply Mode	Power Supply Priority	Max Power Supply(W)	Current (mA)	Operation
GE1	Not powered	802.3af/at	Auto	Low	30.00	--	
GE2	Not powered	802.3af/at	Auto	Low	30.00	--	
GE3	Not powered	802.3af/at	Auto	Low	30.00	--	
GE4	Not powered	802.3af/at	Auto	Low	30.00	--	

Total Power Input prompt

When resetting the Power Sourcing Equipment (PSE) on the GWN7711P switch, a confirmation dialog appears, warning that this action will power off and restart all connected Powered Devices (PDs). The user must acknowledge the risk by selecting the checkbox and clicking "Ok" to proceed.

Confirm to reset PSE?

It will cause the PD device to power off and restart.

I am aware of the risks.

PSE Reset

To edit the PoE parameters on the supported port, click on the **"Edit icon"** under the operation column, then select from the drop-down lists the power supply standard, power supply mode, and power supply priority.

Power Supply Setting > Edit

Port	GE1
Power Supply Standard	802.3af/at
Power Supply Mode	Auto
Power Supply Priority	Low

Power Supply Setting Edit port

PoE Watchdog

The PoE Watchdog feature is designed to monitor the connectivity of Powered Devices (PD) on PoE-enabled ports. The switch periodically sends packets to a configured IP address to check the PD's availability. If the PD does not respond, the switch will disable and re-enable the PoE on that port, effectively rebooting the device. This feature is useful for ensuring the continuous operation of critical devices like IP cameras, access points, or VoIP phones.

PoE Watchdog								
Port	Description	Enable	IP Address	Send Packet Interval (s)	Enable Delay Time (s)	Retries	Disable Time (s)	Operation
GE1	--	Disabled	--	--	--	--	--	
GE2	--	Disabled	--	--	--	--	--	
GE3	--	Disabled	--	--	--	--	--	
GE4	--	Disabled	--	--	--	--	--	

PoE Watchdog

Steps to Configure PoE Watchdog

1. Navigate to **PoE** → **PoE Watchdog** from the web interface.
2. Click on the edit icon next to the port you want to configure.
3. In the edit page, configure the following fields:
 - **Port:** Select the port to monitor.
 - **Description:** (Optional) Describe the port.
 - **Enable:** Toggle to enable or disable PoE Watchdog for this port.
 - **IP Address:** Enter the IP address of the device to ping.
 - **Send Packet Interval (s):** Set the interval between ping packets.
 - **Enable Delay Time (s):** Set the delay time before enabling PoE watchdog.
 - **Retries:** Configure the number of ping retries before considering the device unreachable.
 - **Disable Time (s):** Set the time to disable PoE before re-enabling it.

Note:

The values for "Send Packet Interval," "Enable Delay Time," and "Retries" need to be calculated based on the Powered Device (PD) boot time to ensure successful monitoring and reboot.

PoE Watchdog > Edit

ⓘ PoE port needs to consider the PD device boot time to ensure that the device has been booted and can work normally. Namely: enable delay time + send packet interval * retries ≥ PD boot time

Port: GE1

Description: Port Description (0-32 characters)

Enable:

*IP Address: 192.168.80.22 (IPv4 format)

*Send Packet Interval (s): 30 (Range: 30-3600)

*Enable Delay Time (s): 60 (Range: 60-3600)

*Retries: 2 (Range: 1-10)

*Disable Time (s): 5 (Range: 5-30)

Cancel Save

PoE Watchdog Edit port

MONITORING

Port Statistics

For monitoring or even sometimes troubleshooting, the Flow Statistics displays in real time the flow of data with different units like Octets, Packets, Transmission Rate, and OutErrPackets.

To refresh the statistics, click on the "Refresh" button, and to clear all the statistics click on the "Clear All" button.

To clear the data for a specific port click on the "clear icon" under the operation column.

Port	InPackets	InErrPackets	OutPackets	OutErrPackets	Operation
GE1	0	0	0	0	🔄 🗑️
GE2	0	0	0	0	🔄 🗑️
GE3	0	0	0	0	🔄 🗑️
GE4	0	0	0	0	🔄 🗑️
GE5	0	0	0	0	🔄 🗑️
GE6	829628	0	5791	0	🔄 🗑️
GE7	0	0	0	0	🔄 🗑️
GE8	0	0	0	0	🔄 🗑️

Port Statistics

For more details, click on the "Exclamation mark icon" under the operation column next to each port.

GE6	
Refresh	Clear data
RX Drop Packet	0
RX filtering Packet	737149
RX Unicast Packet	13782
RX Multicast Packet	674894
RX Broadcast Packet	175712
RX Alignment Error Packet	0
RX CRC Packet	0
RX Undersize Packet	0
RX Fragment Error Packet	0
RX Oversize Packet	0
RX Jabber Error Packet	0
RX Pause Packet	0
RX Packet Length < 64 bytes	100480









Port Statistics port details

Port Mirror

Mirroring refers to copying the packets from the specified source to the destination port. The specified source is called the mirroring source, the destination port is called the observing port, and the copied packet is called the mirroring packet.

Mirroring can make a copy of the original packet without affecting the normal processing of the original packet by the device, and send it to the monitoring device through the observation port to determine whether the service running on the network is normal.

GWN771x switch supports up to 4 groups, to configure/edit a group, click on the "Edit icon" under the operation column.

Port Mirror				
Group	Ingress Mirroring Port	Egress Mirroring Port	Monitor Port	Operation
1	--	--	--	 
2	--	--	--	 
3	--	--	--	 
4	--	--	--	 

Port Mirror

To start mirroring a port, first, select the **Ingress** (incoming traffic to the switch) **Mirroring port**, then select the **Egress** (outgoing traffic) **Mirroring port**, and then select from the drop-down list the **Monitor port** (Monitor port cannot be the same as the Mirroring port), please refer to the figure below:

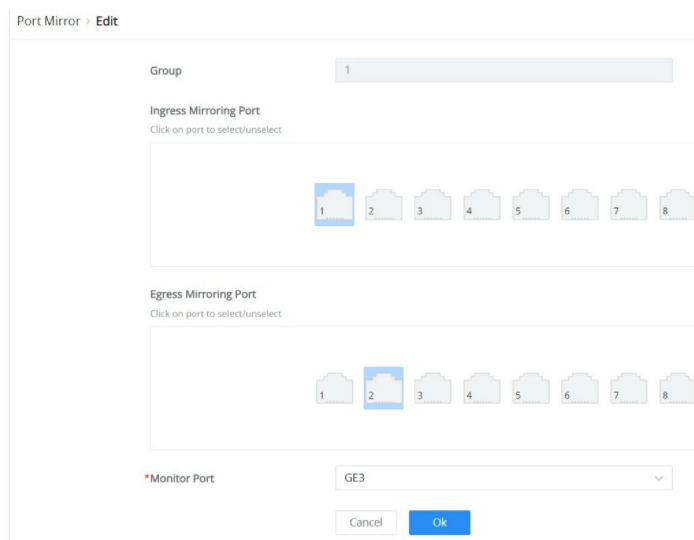

Port Mirror Edit Group

Cable Test

The Cable Test can detect whether the cable connected to the switch is faulty and the location of the fault. Using this function can assist in the daily engineering installation diagnosis.

Please navigate to **Maintenance** → **Cable Test**.

Note:

Please ensure the Ethernet port is down when doing Cable Test. Otherwise, it cannot be detected

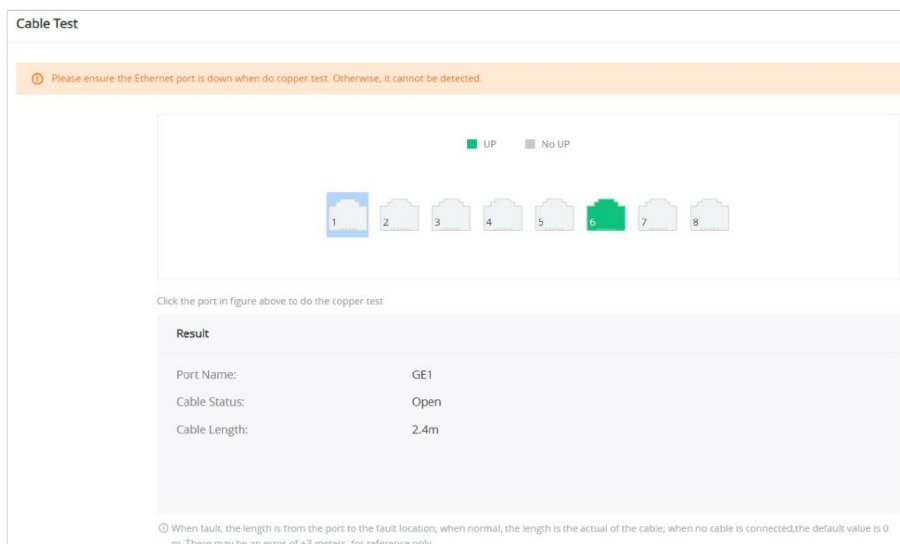

Cable Test

Loopback Detection

The **Loopback Detection** feature helps prevent self-looping on a port, which can disrupt the normal operation of the network. When loopback detection is enabled on a port, if a loop is detected, the port will automatically shut down or take appropriate measures.

Note:

Please note that if Spanning Tree Protocol (STP) is enabled on a port, the loop detection function for that port will not work properly.

Configuration:

1. **Navigate to Monitoring** → **Loopback Detection** on the GWN771x switch's web UI.
2. Toggle **Loopback Detection** on or off.
3. Click **OK** to save the settings.

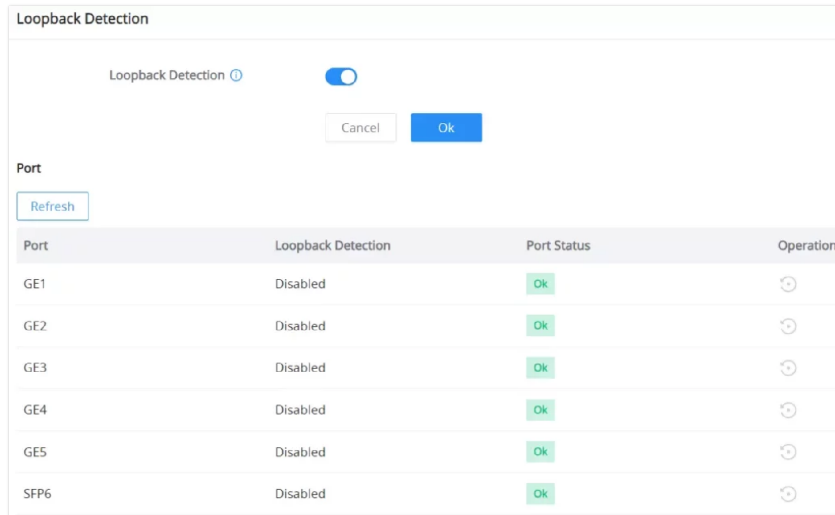

Loopback Detection

Field	Description
Port	The physical port on which the loopback detection settings will be applied.
Loopback Detection	Whether loopback detection is enabled or disabled for the specific port.
Port Status	The current operational status of the port. It shows whether the port is functioning normally ('OK') or if there is a fault or loop ('Error').
Operation	The available actions for the port. For ports that have been disabled due to loop detection the 'Restore' option will appear to re-enable them.

Loopback Detection

MAINTENANCE

Upgrade

GWN771x Switches support manual upload firmware upgrade via a BIN file that can be downloaded from the Grandstream Firmware page: <https://www.grandstream.com/support/firmware>

Upgrade Via Network is also supported by specifying the Firmware Server Path (For example firmware.grandstream.com).

Upgrade

Current version: 1.0.0.20

Upgrade via Manual Upload

Upload Firmware File to Update: Supported file formats: bin

Upgrade via Network

Allow DHCP Option 43/160/66 to Override Server On Off Prefer, fallback when failed

Firmware Upgrade Protocol

Firmware Server Path 0-128 characters

HTTP Username 0-32 characters

HTTP Password 0-32 characters

Upgrade

Backup & Restore

On this page, the user can back up the configuration, restore from a previously saved configuration file or factory reset the GWN771x.

- **Backup:** The current switch configuration can be exported and saved to your computer. In the future, if you need to restore this configuration, you can simply import the backup file.
- **Restore:** The switch configuration can be restored based on the imported configuration file. If the device fails to be restored, hold down the Pinhole button on the back of the switch for five seconds to restore the switch to factory settings.
- **Factory Reset:** After factory restoration, all configurations of the switch will be restored to factory defaults. Please use it with caution! You are recommended to back up the current configuration before factory restoration.

Backup & Restore

Backup

The current switch configuration can be exported and saved to your computer. In the future, if you need to restore this configuration, you can simply import the backup file.

Restore

The switch configuration can be restored based on the imported configuration file. If the device fails to be restored, hold down the Pinhole button on the back of the switch for five seconds to restore the switch to factory settings.

Factory Reset

After factory restoration, all configurations of the switch will be restored to factory defaults. Please use with caution! You are recommended to back up the current configuration before factory restoration.

Backup Restore

Ping

The user on this page can enter the IP Address or Hostname and then click "**Start**", the results of the ping command will be shown below.

Ping

*IP Address/Hostname: 192.168.125.190

*Packet Count: 4 Range: 1-65535

Start

Results

Host Address:	192.168.125.190
Number of Packets sent:	4
Number of Packets Received:	4
Packet Lost:	0 %
Minimum Round Trip Time:	4 ms
Maximum Round Trip Time:	5 ms
Average Round Trip Time:	4 ms
Status:	Ping succeed

Ping

SNMP

The Simple Network Management Protocol (SNMP) feature allows network administrators to monitor and manage devices within the network. The SNMP feature can be configured to send notifications and traps to an SNMP manager, helping to ensure efficient network operations.

Global Settings – SNMP

The **Global Settings** tab in the SNMP section allows administrators to configure community strings for SNMPv2 operations.

To access SNMP Global Settings:

1. Navigate to **Maintenance** → **SNMP** → **Global Settings**.
2. Enable SNMP by toggling the switch to **ON**.

SNMP

Global Settings Notification Management Trap Event

SNMPv2

*Read Community: public 1-32 characters

*Write Community: private 1-32 characters

*Trap Community: public 1-32 characters

SNMP Global settings

Field Name	Description	Character Limit/Range
Read Community	Defines the community string for read-only access.	1-32 characters
Write Community	Defines the community string for read-write access.	1-32 characters
Trap Community	Defines the community string for sending SNMP traps to the manager.	1-32 characters

SNMP Global Settings Field Descriptions

Notification Management

The **Notification Management** tab allows the configuration of the SNMP trap server and port.

To configure the trap server:

1. Navigate to **Maintenance** → **SNMP** → **Notification Management**.
2. Set the following fields:
 - **Server Address:** Specify the IP address of the SNMP trap server.
 - **UDP Port:** Enter the port used for SNMP trap communication (default is 162).

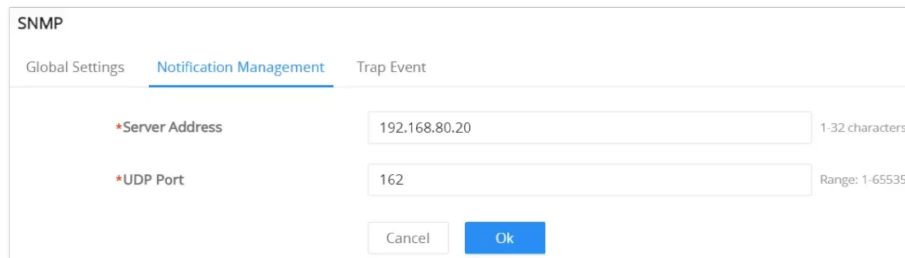

The screenshot shows a configuration dialog box titled "SNMP". It has three tabs: "Global Settings", "Notification Management" (which is selected and highlighted in blue), and "Trap Event". Under the "Notification Management" tab, there are two input fields. The first is labeled "*Server Address" and contains the value "192.168.80.20". To the right of this field is the text "1-32 characters". The second field is labeled "*UDP Port" and contains the value "162". To the right of this field is the text "Range: 1-65535". At the bottom of the dialog, there are two buttons: "Cancel" and "Ok".

SNMP Notification Management

Trap Event

The **Trap Event** tab allows administrators to select the specific events for which SNMP traps should be sent to the SNMP manager.

To configure SNMP traps:

1. Navigate to **Maintenance** → **SNMP** → **Trap Event**.
2. Enable the desired trap events by toggling their switches. The available events are:
 - **Authentication Failed**
 - **Port Up/Down**
 - **Cold Start**
 - **Warm Start**
 - **STP Bridge**
 - **Port ErrDisable**
 - **PoE Power Supply**
 - **VLAN Creation**
 - **VLAN Deletion**
 - **Configuration File Distribution**

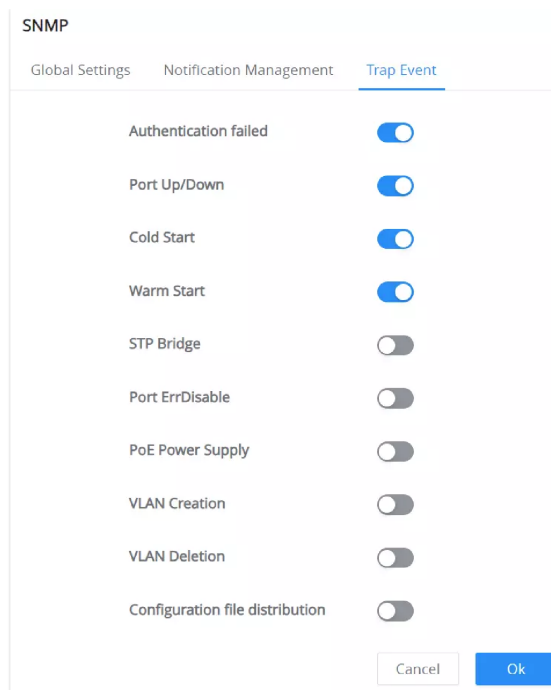

The image shows the 'SNMP Trap Event' configuration window. It has three tabs: 'Global Settings', 'Notification Management', and 'Trap Event'. The 'Trap Event' tab is selected. Below the tabs, there is a list of ten event types, each with a toggle switch. The first four events (Authentication failed, Port Up/Down, Cold Start, Warm Start) have their toggle switches turned on (blue). The remaining six events (STP Bridge, Port ErrDisable, PoE Power Supply, VLAN Creation, VLAN Deletion, Configuration file distribution) have their toggle switches turned off (grey). At the bottom right, there are 'Cancel' and 'Ok' buttons.

Event Type	Status
Authentication failed	On
Port Up/Down	On
Cold Start	On
Warm Start	On
STP Bridge	Off
Port ErrDisable	Off
PoE Power Supply	Off
VLAN Creation	Off
VLAN Deletion	Off
Configuration file distribution	Off

SNMP Trap Event

LLDP

The Link Layer Discovery Protocol (LLDP) allows the switch to advertise its identity, capabilities, and status to neighboring devices in the network. LLDP helps administrators efficiently monitor and manage network devices by providing detailed information about devices connected to the network.

Global Settings

To access LLDP Global Settings:

1. Navigate to **Maintenance** → **LLDP** → **Global Settings**.
2. Enable LLDP by toggling the switch to **ON**.

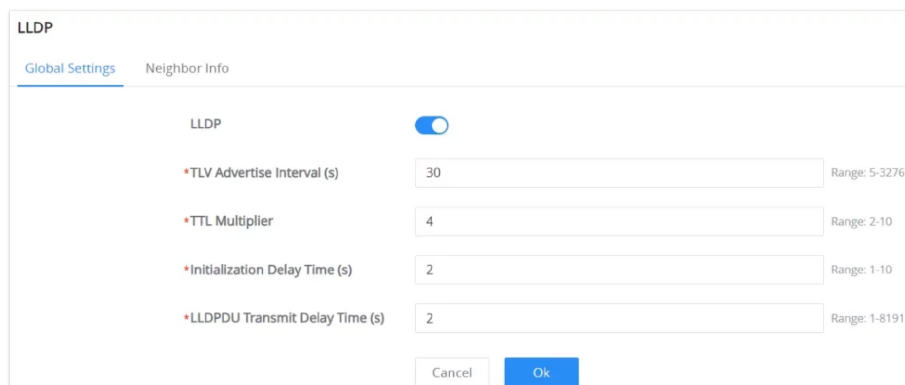

The image shows the 'LLDP Global Settings' configuration window. It has two tabs: 'Global Settings' and 'Neighbor Info'. The 'Global Settings' tab is selected. At the top, there is a toggle switch for 'LLDP' which is turned on (blue). Below this, there are four input fields for LLDP parameters, each with a range indicator to its right. The values entered in the fields are: 30 for TLV Advertise Interval (s), 4 for TTL Multiplier, 2 for Initialization Delay Time (s), and 2 for LLDPDU Transmit Delay Time (s). At the bottom, there are 'Cancel' and 'Ok' buttons.

Parameter	Value	Range
*TLV Advertise Interval (s)	30	5-32767
*TTL Multiplier	4	2-10
*Initialization Delay Time (s)	2	1-10
*LLDPDU Transmit Delay Time (s)	2	1-8191

LLDP Global settings Enabled

When LLDP is disabled, the system provides two handling options:

- **Filter:** Stops LLDP packets at the device, using LLDP only for local neighbor information.
- **Bridge:** Forwards LLDP packets to other devices, enabling broader network discovery.

Select the desired LLDP handling method, then click **OK**.

LLDP Global settings Disabled

Field Name	Description	Range
If LLDP is disabled		
Filter	stops LLDP packets at the device, using LLDP only for local neighbor information.	–
Bridge	forwards LLDP packets to other devices, enabling broader network discovery.	–
If LLDP is enabled		
TLV Advertise Interval (s)	Defines the interval (in seconds) at which LLDP advertisements are sent to neighboring devices.	5 – 32767
TTL Multiplier	Specifies the Time-to-Live (TTL) multiplier for LLDP data units, determining their expiration time.	2 – 10
Initialization Delay Time (s)	Configures the delay time before LLDP starts after being enabled.	1 – 10
LLDPDU Transmit Delay Time (s)	Determines the delay between transmissions of LLDP Data Units (LLDPDU).	1 – 8191

LLDP Global Settings Field Descriptions

Port Settings

The **Port Settings** section allows the configuration of LLDP operation on a per-port basis. Users can specify how LLDP should behave on each port and select which TLV (Type-Length-Value) elements to include in the advertisements.

To configure LLDP per port:

1. Under the **Global Settings** tab, scroll down to **Port Settings**.
2. Click **Edit** next to the desired port to modify its LLDP configuration.

Port	Working Mode	TLV	Operation
<input checked="" type="checkbox"/> GE1	Tx&Rx	Basic TLV (6), IEEE 802.1 TLV (2), IEEE 802.3 TLV (4)	
<input checked="" type="checkbox"/> GE2	Tx&Rx	Basic TLV (5), IEEE 802.1 TLV (1), IEEE 802.3 TLV (3)	
<input checked="" type="checkbox"/> GE3	Tx&Rx	Basic TLV (5), IEEE 802.1 TLV (1), IEEE 802.3 TLV (3)	
<input type="checkbox"/> GE4	Tx&Rx	Basic TLV (5), IEEE 802.1 TLV (1), IEEE 802.3 TLV (3)	
<input type="checkbox"/> GE5	Tx&Rx	Basic TLV (5), IEEE 802.1 TLV (1), IEEE 802.3 TLV (3)	
<input type="checkbox"/> GE6	Tx&Rx	Basic TLV (5), IEEE 802.1 TLV (1), IEEE 802.3 TLV (3)	
<input type="checkbox"/> GE7	Tx&Rx	Basic TLV (5), IEEE 802.1 TLV (1), IEEE 802.3 TLV (3)	
<input type="checkbox"/> GE8	Tx&Rx	Basic TLV (5), IEEE 802.1 TLV (1), IEEE 802.3 TLV (3)	

LLDP Port Settings

LLDP Global Settings > **Edit**

Port: GE1

Working Mode: Tx&Rx

TLV

Basic TLV

Port Description TLV System Name TLV

System Description TLV System Capabilities TLV

Management Address TLV PoE-PSE TLV

IEEE 802.1 TLV

Port VLAN ID TLV VLAN Name TLV

IEEE 802.3 TLV

MAC/PHY Configuration/Status TLV Link Aggregation TLV

Maximum Frame Size TLV Power via MDI TLV

Cancel Ok

LLDP Edit port

Field Name	Description
Port	Specifies the port being configured.
Working Mode	Select whether the port should <ul style="list-style-type: none"> • Transmit (Tx) • Receive (Rx) • Transmit and Receive (Tx&Rx) • Disable LLDP on that port
TLV	Select which Type-Length-Value (TLV) elements to advertise.

LLDP Port Settings Field Descriptions

Neighbor Info

The **Neighbor Info** tab provides detailed information about the devices connected to the switch via LLDP. This includes the identity, chassis ID, and port information for each neighboring device.

To access Neighbor Info:

1. Navigate to **Maintenance** → **LLDP** → **Neighbor Info**.
2. The page will display the following information for each neighboring device:
 - **Local Port:** The local port connected to the neighbor.
 - **Chassis ID:** The chassis ID of the neighboring device.
 - **Neighbor Port ID:** The port on the neighboring device that is connected to the switch.
 - **Device Name:** The name of the neighboring device.
 - **System Description:** A description of the neighboring device.
 - **Survival Time (TTL):** The remaining time before the neighbor's LLDP data expires.
3. Click **Refresh** to update the information, or **Delete** to remove neighbor entries.

LLDP

Global Settings **Neighbor Info**

Refresh Delete

Local Port	Chassis ID Subtype	Chassis ID	Neighbor ID Subtype	Neighbor Port ID	Device Name	System Description	Survival Time TTL (s)	Operation
<input type="checkbox"/> GE8	MacAddr	c0:74:ad:ba:24:fc	Local	eth1/0/4	GWN7803P	GWN7803P	111	

Total 1 < 1 > 10 / page

LLDP Neighbor Info

LED Indicators

The LED indicators (power, port, and PoE indicators) can be toggled ON or OFF through the web interface. This feature allows users to disable the LEDs when needed, providing a cleaner and more discreet appearance while maintaining full functionality.

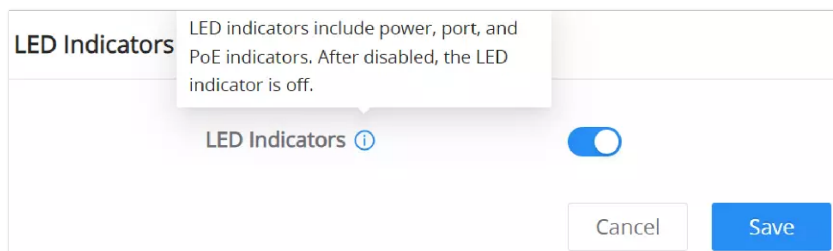

LED Indicators

To configure the LED indicators:

1. Log in to the switch's web interface.
2. Navigate to **Maintenance** → **LED Indicators**.
3. Toggle the switch next to **LED Indicators** to enable or disable all LED lights.
4. Click **Save** to apply the settings.

Once disabled, no LED feedback for power, port activity, or PoE states will be shown.

Note:

This feature is currently supported only on the GWN7710R.

CHANGE LOG

This section documents significant changes from previous versions of the GWN7711(P)/GWN7710R switches user manuals. Only major new features or major document updates are listed here. Minor updates for corrections or editing are not documented here.

Firmware Version 1.0.7.9

Product name: GWN7711, GWN7711P, GWN7710R

- o Added 802.1Q VLAN filtering. [[802.1Q VLAN](#)]
- o Added VLAN Transparent transmission for 802.1Q VLANs. [[802.1Q PVID Settings](#)]
- o Updated ingress filtering behavior to allow all VLANs. [[Rate Limit](#)]
- o Added device temperature reporting to GCC management. [[Management Platform](#)]
- o Added cloud-side validation and error when an unsupported total PoE input is configured for GWN7710R. [[Management Platform](#)]
- o Added error handling when the global Voice VLAN is not set as tagged or untagged and provisioning fails. [[Global Settings – Voice VLAN](#)]
- o Updated Voice VLAN to support the Tagged OUI type on GWN771x. [[Global Settings – Voice VLAN](#)]
- o Added missing HTTP security response headers.
- o Set the default total power to 120W at startup when using a 12V power supply on GWN7711P. [[Power Supply Setting](#)]

- Updated LLDP to display Link Aggregation information under the IEEE 802.3 TLV. [[LLDP](#)]
- Added VLAN Transparent forwarding support in the IGMP module. [[IGMP SNOOPING](#)]
- Added safeguard prompt indicating that VLAN 1, the Management VLAN, and the Voice VLAN cannot be deleted when using "Delete All." [[802.1Q VLAN](#)]

Firmware Version 1.0.3.21

Product name: GWN7711, GWN7711P, GWN7710R

- Added support for [[Voice VLAN](#)].
- Added support to set PoE input total power via Cloud. [[Power Supply Setting](#)]

Firmware Version 1.0.3.13

Product name: GWN7711, GWN7711P, GWN7710R

- No Major Changes.

Firmware Version 1.0.3.11

Product name: GWN7711, GWN7711P, GWN7710R

- Added support for LLDP features. [[LLDP](#)]
- Added support for SNMP features. [[SNMP](#)]
- Added support for spanning tree features. [[Spanning Tree](#)]
- Added support for management VLAN configuration. [[Management VLAN](#)]
- Added support for DHCP Snooping features. [[DHCP Snooping](#)]
- Added support for PoE ping watchdog features. [[PoE Watchdog](#)]
- Added support for ',' character for password. [[Change Password](#)]
- Added support for MAC address input with a hyphen-separated format in the MAC fields. [[MAC Address Search](#)]
- Added support for the latest GDMS Networking features. [[Management Platform](#)]
- Added support for the latest GWN Manager features. [[Management Platform](#)]
- GWN7710R added support for configuring all LED lights ON or OFF through the webpage. [[LED Indicators](#)]
- Added Loop Detection status to the Loop Detection list, and changed the status of the table header to Port Status. [[Loopback Detection](#)]

Firmware Version 1.0.1.25

Product name: GWN7711, GWN7711P, GWN7710R

- No major changes.
- This is the initial version for GWN7710R.

Firmware Version 1.0.1.22

Product name: GWN7711, GWN7711P

- Added support for GDMS Networking and GWN Manager. [[Manager Settings](#)]
- Added the cloud connection status icon. [[Manager Settings](#)]
- Added the risk alarm for PSE reset. [[Power Supply Setting](#)]
- Added prompt when saving the PoE function. [[Power Supply Setting](#)]

Firmware Version 1.0.0.8

Product name: GWN7711, GWN7711P

- This is the initial release.

